

Long Form - Storm Water Data Report



Dist-County-Route: 05-MON-68

Post Mile (Kilometer Post) Limits: 6.1/L6.9(3.8/L4.3)

Project Type: Widening

EA: 448000

RU: 111

Program Identification: Private Developer Fund w/ City and County of Monterey STIP and RSRP

Phase: []PID [x]PA/ED []PS&E

Regional Water Quality Control Board(s): Region 3 - Central Coast

Is the project required to consider incorporating Treatment BMPs? [x]Yes []No

If yes, can Treatment BMPs be incorporated into the project? [x]Yes []No

If No, a Technical Data Report must be submitted to the RWQCB

at least 60 days prior to PS&E Submittal. List submittal date: May 2008

Total Disturbed Soil Area: 1.9 ha (4.77 ac)

Estimated Construction Start Date: 04-2013 Construction Completion Date: 10-2014

Notification of Construction (NOC) Date to be submitted: 03-2013

Notification of ADL reuse (if Yes, provide date) []Yes Date: []No

Separate Dewatering Permit (if Yes, permit number) []Yes Permit #: []No

This Report has been prepared under the direction of the following Licensed Person. The Licensed Person attests to the technical information contained herein and the data upon which recommendations, conclusions, and decisions are based. Professional Engineer or Landscape Architect stamp required at PS&E.

Richard Tanaka Registered Project Engineer/Landscape Architect Date

I have reviewed the storm water quality design issues and find this report to be complete, current, and accurate:

Dave Rasmussen Project Manager Date

David Perez Designated Maintenance Representative Date

Dennis Reeves Designated Landscape Architect Representative Date

Marissa Nishikawa District/Regional SW Coordinator or Designee Date

APPENDIX E

Long Form - Storm Water Data Report

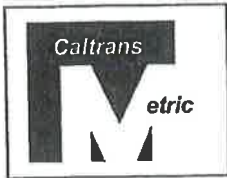

Dist-County-Route 05-MON-68
 Kilometer Post (Post Mile) Limits 6.1/L6.9(3.8/L4.3)
 Project Type **Widening**
 EA: 448000
 RU: 111
 Program Identification: Private Developer Fund w/
City & County of Monterey STIP and RSTP
 Phase: PID PA/ED PS&E

Regional Water Quality Control Board(s): Region 3 - Central Coast Region

Is the project required to consider incorporating Treatment BMPs? Yes No

If yes, can Treatment BMPs be incorporated into the project? Yes No

If No, a Technical Data Report must be submitted to the RWQCB at least 30 days prior to Advertisement. List submittal date: _____

Total Disturbed Soil Area: 1.9 ha (4.77 ac)

Estimated: Construction Start Date: 04/2008 Construction Completion Date: 12/2009

Notification of Construction (NOC) Date to be submitted: 03/2008

Notification of ADL reuse (if Yes, provide date) Yes Date _____ No

Separate Dewatering Permit (if Yes, permit number) Yes Permit # _____ No

This Report has been prepared under the direction of the following Licensed Person. The Licensed Person attests to the technical information contained herein and the data upon which recommendations, conclusions, and decisions are based. Professional Engineer or Landscape Architect stamp required at PS&E.

 05-10-06
 Richard K. Tanaka, Registered Project Engineer Date

I have reviewed the storm water quality design issues and find this report to be complete, current, and accurate:

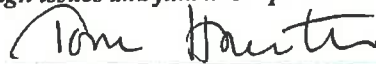
 5-25-06
 Tom Houston, Project Manager Date

 6-5-06
 Jon Wood, Designated Maintenance Representative Date

 5/30/06
 Dennis Reeves, Designated Landscape Architect Representative Date

 6/8/06
 FOR Darren Cousineau, District/Regional SW Coordinator or Designee

STAMP
[Required for PS&E only]
Date

STORM WATER DATA INFORMATION

1. Project Description

The City of Monterey proposes to widen and upgrade 0.8 kilometer of Route 68 (Holman Highway) to a four-lane facility in the County of Monterey from 0.2 kilometer west of the Community Hospital of Monterey Peninsula (CHOMP) Entrance to the Route 1/Route 68 Junction. Route 1 southbound off-ramp and southbound on-ramp improvements are also included in the project. The preliminary project cost estimate is about \$21.12 million. The project is proposed to be funded primarily by private development sources (Pebble Beach Company and CHOMP) and the City of Monterey as the lead agency (City and TAMC RIP Funds).

More specifically, the following items of work are included:

- ✓ Traffic signals at the intersection of SR 68 and the SR 1 off and on ramps would be modified.
- ✓ Traffic signal at the SR 68/CHOMP Entrance would be modified;
- ✓ The Scenic Drive overcrossing would be replaced with a new bridge;
- ✓ The Beverly Manor Development Entrance would be redesigned to prohibit left turns out of the entrance to eastbound SR 68. Eastbound left turns from SR 68 to the Beverly Manor Development Entrance and right turns in and right turns out of the entrance will be allowed;
- ✓ SR 1 southbound off- and onramps would require widening and installation of retaining walls;
- ✓ The Pebble Beach Entrance would be modified; and
- ✓ The proposed retaining walls (in 5 different areas) would be constructed at the edge of right-of-way.

The total disturbed soil area for this project is 1.9 ha (4.77 ac). The accounted areas are new pavement, clearing and grubbing, retaining wall construction, temporary construction staging areas, contractor's storage yard, haul road and cut and fill limits of the project.

The Project Study Report (PSR) for the proposed highway widening was approved in December 2000. Draft Project Report was approved on September 2006. Since the completion of the PSR and Draft PR, there have been two separate development projects within the project limits which have been approved by the City of Monterey and the County of Monterey. These two projects are improvements to the CHOMP (hospital) and to the Pebble Beach Lot Development. As part of their mitigations, CHOMP is required to improve the intersection of SR 68/CHOMP Entrance and Pebble Beach Company is required to improve access to Pebble Beach Main Gate. CHOMP portion of the work was just completed (February 2008).

It is anticipated that the remaining project will be constructed in two separate phases as follows:

Phase 1 will be the construction of the southbound onramp and the modification to the Pebble



Beach Entrance. This improvement is required as part of the mitigation the Pebble Beach Development Project.

Phase 2 will be the remainder of the project, which the City of Monterey will take the lead and will be the agency responsible for final design and construction.

Construction funding for the SR 68 four-lane widening improvement is included in the 2005 Monterey County Regional Transportation Plan as "Constrained Regional Project".

2. Define Site Data and Storm Water Quality Design Issues (refer to Checklists SW-1, SW-2, and SW-3)

- The Central Coast Regional Water Quality Control Board (CCRWQCB) has jurisdiction over the project limits.
- The closest receiving water within the project limit is the Pacific Ocean. The majority of the runoff from the project site is flowing from east to west toward a 360 mm RCP near the Pebble Beach Entrance gates. This will discharge into the City's drainage system and eventually flow into the Pacific Ocean.
- There is no 303 Listed water body in the vicinity of the project.
- The potential pollutants within the project area include oil, grease, petroleum products, battery acid, metals and other toxic material from cars, bacteria from animal wastes, litter and general debris from traveling public and adjacent properties.
- 401 Certification will be required as a compliance with the Federal permit.
- There are no seasonal construction restrictions. The rainy season has been defined by the Central Coast RWQCB as October 15 through April 15.
- The County of Monterey has an average annual precipitation of 43 inches. In the Southern part of the County, precipitation can get as high as 50 inches per year. Approximately 90 percent of the rainfall occurs between November through April. Measurable precipitation averages 51 days per year, and the average length of the growing season is 235 days.
- The general climate of County of Monterey is characterized as warm, dry summer and cool, moist winter. The average temperature is approximately 56° F.
- The soils in Monterey County vary considerable. There are silicon/quartz deposits along the beaches. To the east of the County toward Salinas, there are alluvial deposits that form some of the finest farmlands in the nation. There are rolling hills that are heavily wooded. The soils in these areas are of sediment origin, but not particularly suited for agriculture. Based on a soil investigation by USR in 2001, there are no active faults within the project limit. The potential for liquefaction and lurch cracking is very low.
- There are no contaminated or hazardous soils within project limits.
- Disturbed area is about 1.9 hectares (4.77 ac). The disturbed area include cut/fill slopes, contractors use area, temporary service roads, and stockpile/borrow areas. The calculated area is approximate.
- The topography of the Monterey County is extremely varied. Elevations range from sea level to 1781 meters (5844 feet) at Junipero Serra Peak, which is about 19 km (12 miles)



inland, in the Santa Lucia range. The County includes the famous Salinas Valley, which is bounded by the Galiban Mountains to the East and the Santa Lucia Mountains to the west. The valley is 13 km to 32 km (10 to 20 miles) wide, 209 km (130 miles) long and has approximately 259,000 hectares (640,000 acres) of broad bottom land. The topography of the site is generally flat trending from North to South. However, the site is situated with high steep hill to the north and low steep terrain to the south.

- Contractor's staging yard and trailer facilities may be located outside of Caltrans' right-of-way. (Contractors yard will be included in SWPPP for project)
- There are slope stabilization concerns in areas where slopes are 1:2 (v:h.)
- Right of way certification will be required due to the right of way acquisition for the widening of the project.
- The project alignment is chosen to maximize the cut and fill balance. Concentrated flows will be collected by culvert systems.
- The land use within project ranges from commercial to residential. To the West of the project, there are the Community Hospital of Monterey Peninsula (CHOMP), and the Beverly Manor Healthcare Center and the Carmel Hill Professional Center. To the east is the Pebble Beach Entrance which is the gateway to the famous Seventeen Mile Drive. Some residential neighborhood are located east of the project and north of the Scenic Drive Overcrossing.

3. Regional Water Quality Control Board Agreements

There are no negotiated understandings or agreements with the Central Coast RWQCB pertaining to this project. The preparation of this SWDR is a specific requirement of the Caltrans NPDES.

4. Describe Proposed Design Pollution Prevention BMPs to be used on the Project.

Downstream Effects Related to Potentially Increased Flow, Checklist DPP-1, Parts 1 and 2

- The project will slightly increase the velocity and volume of flow within the project limits, but should have a negligible effect on downstream flow. Majority of the water will be conveyed by concrete curb and gutter and culvert system through the project site with a maximum velocity of 0.8 m/s during a 25-year storm event. Storm culverts will be fitted with Flared End Sections (FES) and energy dissipation in the form of Rock Slope Protection (RSP) at the outlets to ensure smooth transition and also prevent scour.
- New lined ditches will also be constructed within the project areas to intercept the storm water sheet flowing from the pavement. Ditch slopes will be designed to minimize the velocity of flow to reduce the scour and erosion damages.

Slope/Surface Protection Systems, Checklist DPP-1, Parts 1 and 3

- The project will create several new fill slope surfaces and disturb several existing surfaces. New slope surfaces are proposed at the SB Route 1 on-ramp, SB Route 1 off-ramp, and along some part of Highway 68. In general, the new slopes are 1:4 or flatter.



Long Form - Storm Water Data Report

- Disturbed slopes will be protected with either erosion control Type B or Type C in accordance with the State Standard Specification. The goal during construction will be to implement permanent erosion control measures as soon as possible. Depending on the time of year, these measures can be implemented anytime during construction. A detailed erosion control plans will be prepared at the PS&E phase.
- SSPs 07-390, 20-010, 20-030, 20-040, 20-350 and 72-010 will be included in the project special provision at PS&E phase.
- The estimated existing vegetated surface area within the project limits is about 0.28 ha.
- There is no existing hard surface BMP.
- Approximately more the 460 trees will be removed as part of the construction of this project. Majority of these trees are native Monterey pines. A mitigation plan is currently proposed and the details will be available in the PS&E phase.

Concentrated Flow Conveyance Systems, Checklist DPP-1, Parts 1 and 4

- Generally, the runoff will be conveyed through closed conduits and concrete curbs before discharging into the City's drainage system. However, erosion control measures will be implemented to minimize depositing additional sediment. Roadway facilities are not anticipated to subject to flooding in this project.
- Detailed design of concentrated conveyance systems will be done in the PS&E phase.

Preservation of Existing Vegetation, Checklist DPP-1, Parts 1 and 5

- Based on the preliminary design, the project will involve clearing and grubbing of about 1.57 hectares (3.88 acres).
- Preservation areas will be identified on the contract plans and protected with fence during construction.

5. Describe Proposed Permanent Treatment BMPs to be used on the Project

This project meets the definition of major reconstruction project and the project is also in the urban area subject to a MS4 permit. Therefore, Treatment BMPs would need to be considers for this project (see Evaluation Documentation Form included in Appendix). The Targeted Design Constituent (TDC) will be identified at the PS&E phase and will discuss with the storm water coordinator to select the approved Treatment BMPs.

Treatment BMP Strategy, Checklist T-1

- Existing impervious area is 2.14 hectares (5.29 acres) within the project limits. This project is adding an additional 1.18 hectares (2.92 acres) for a total of 3.32 hectare (8.20 acres) of impervious surface. It is intended to treat 100% of the runoff from this project. A preliminary estimate shows that 61% of the total impervious surface will be treated with the new BMP. The rest of the flow will follow its original drainage pattern. A detail design will be submitted for review at the PS&E phase.

Biofiltration Swales/Strips, Checklist T-1, Parts 1 and 2



- Biofiltration and biostrips will be looked at in the PS&E phase.

Dry Weather Diversion, Checklist T-1, Parts 1 and 3

- Dry weather diversion is not applicable for this project.

Infiltration Devices – Checklist T-1, Parts 1 and 4

- Infiltration basins will be looked at the PS&E phase.

Detention Devices, Checklist T-1, Parts 1 and 5

- Detention basins will be looked at the PS&E phase.

Gross Solids Removal Devices (GSRDs), Checklist T-1, Parts 1 and 6

- GSRDs are not applicable for this project.

Traction Sand Traps, Checklist T-1, Parts 1 and 7

- Traction Sand Traps are not applicable for this project.

Media Filters, Checklist T-1, Parts 1 and 8

- Media Filters will be looked at the PS&E phase.

Multi-Chambered Treatment Trains (MCTTs), Checklist T-1, Parts 1 and 9

- MCTTs are not applicable for this project.

Wet Basins, Checklist T-1, Parts 1 and 10

- Wet Basins are not applicable for this project

6. Describe Proposed Temporary Construction Site BMPs to be used on Project

Temporary construction site BMP such as temporary silt fence, temporary ESA fence, temporary fiber rolls, fiber roll check dams, temporary soil stabilizers, temporary erosion control, temporary construction entrances/exits, temporary construction road, temporary concrete washouts, temporary stockpile covers, temporary creek diversion and temporary drain inlet protection will be incorporated into the design during the PS&E phase. The preliminary cost estimate for the temporary construction site BMP is \$150,000 which is 1% of the total construction cost for the project. A more detail cost estimate for temporary BMP will be provided at the PS&E phase.

In addition, measures identified in Caltrans SSP 07-345 such as but not limited to street sweeping, construction waste management, and tracking control will also be included.

Permanent erosion control will be implemented as soon the slopes are complete by incorporating erosion control as separate contract item.



Long Form - Storm Water Data Report

Construction costs for permanent BMPs are included in the Preliminary Project Construction Cost Estimate Summary (PPCE) associated with storm water pollution prevention and treatment. A brief summary is as follows:

Roadway Items

- Section 1: Earthwork
 - Total \$484,000

- Section 2: Temporary Construction BMP's
 - Temporary Erosion Control
 - Temporary Drainage Protection
 - Temporary Fiber Roll
 - Total \$100,000

- Section 3: Drainage
 - Concentrate Flow Conveyance System
 - AC dike
 - Ditches
 - Total \$ 80,000

- Section 4: Specialty Items
 - Erosion Control, (Type D)
 - Erosion Control Blanket
 - Slope Protection (Backing No. 2, Method B)
 - Biofiltration Strips/Swales
 - Total \$50,000

- Section 5: Treatment BMP's
 - Treatment BMP \$100,000

TOTAL STORM WATER TREATMENT & PREVENTION: \$330,000

7. Maintenance BMPs (Drain Inlet Stenciling)

Inlet stenciling will be required by the City of Monterey. The template will be provided by the City of Monterey.

REQUIRED ATTACHMENTS

- Evaluation Documentation Form (EDF)



Long Form - Storm Water Data Report

- Treatment BMP Summary Spreadsheets
- Treatment BMP Consideration
- Attachment A – Location Map
- Attachment B – Project GAD
- Attachment C – Typical Cross Sections
- Attachment D – Rainfall Intensity Duration/Frequency Data Sheet
- Attachment F – Disturbed Soil Area Exhibit

SUPPLEMENTAL ATTACHMENTS

- Storm Water BMP Cost Summary (IN PROGRESS)
- Project Report Cost Estimate
- Checklist SW-1, Site Data Sources
- Checklist SW-2, Storm Water Quality Issues Summary
- Checklist SW-3, Measures for Avoiding or Reducing Potential Storm Water BMPs
- Checklists DPP-1, Parts 1–5 (Design Pollution Prevention BMPs)
- Checklists T-1 through Part 10 (Treatment BMPs)



Evaluation Documentation Form

DATE: 05-02-08

See Figure 4-1, Project Evaluation Process for Consideration of Permanent Treatment BMPs EA: 448000

NO.	CRITERIA	YES	NO	SUPPLEMENTAL INFORMATION FOR EVALUATION
1.	Begin Project Evaluation regarding requirement for consideration of Treatment BMPs	<input checked="" type="checkbox"/>		Go to 2
2.	Is this an emergency project?	<input type="checkbox"/>	<input checked="" type="checkbox"/>	If Yes , go to 11. If No , continue to 3.
3.	Have TMDLs OR OTHER Pollution Control Requirements been established for surface waters within the project limits?	<input type="checkbox"/>	<input checked="" type="checkbox"/>	If Yes , contact the District/Regional NPDES coordinator to discuss the Department's obligations under the TMDL (if Applicable) or Pollution Control Requirements, go to 10 or 4 (as determined by the NPDES Coordinator). _____ (Dist./Reg. SW Coordinator initials) If No , continue to 4.
4.	Is the project within an urban MS4?	<input checked="" type="checkbox"/>	<input type="checkbox"/>	If Yes , continue to 5. <i>City of Monterey MS4</i> If No , go to 11.
5.	Is the project directly or indirectly discharging to surface waters?	<input checked="" type="checkbox"/>	<input type="checkbox"/>	If Yes , continue to 6. If No , go to 11.
6.	Is this a new facility or major reconstruction?	<input checked="" type="checkbox"/>	<input type="checkbox"/>	If Yes , continue to 8. If No , go to 7.
7.	Will there be a change in line/grade or hydraulic capacity?	<input type="checkbox"/>	<input type="checkbox"/>	If Yes , continue to 8. If No , go to 11.
8.	Is the Disturbed Soil Area (DSA) created by the project <u>greater than or equal to 3.0 acres</u> or does the project result in a <u>net increase of one acre or more of new impervious surface</u> ?	<input checked="" type="checkbox"/>	<input type="checkbox"/>	If Yes , continue to 10. If No , go to 9. <i>1.9 ha</i>
9.	Is the project part of a Common Plan of Development?	<input type="checkbox"/>	<input type="checkbox"/>	If Yes , continue to 10. If No , go to 11.
10.	Project is required to consider approved Treatment BMPs.	<input checked="" type="checkbox"/>		See Sections 2.4 and either Section 5.5 or 6.5 for BMP Evaluation and Selection Process. Complete Checklist T-1 in this Appendix E.
11.	Project is not required to consider Treatment BMPs. _____ (Dist./Reg. SW Coord. Initials) _____ (Project Engineer Initials) _____ (Date)	<input type="checkbox"/>		Document for Project Files by completing this form, and attaching it to the SWDR.

See Figure 4-1, Project Evaluation Process for Consideration of Permanent Treatment BMPs



Treatment BMP Summary Spreadsheet

Dist-County-Route:	05-MON-68
Kilometer Post (Post Mile) Limits:	KP 6.1/L6.9 (PM 3.8/L4.3)
Project Type:	Widening
EA:	05-44800K
RU:	
Program Identification:	Private Fund by Pebble Beach Company, and CHOMP. City and County of Monterey's STIP & RSTP
Phase:	PA/ED
Date:	10/07/05

Infiltration Basins

District-County-Route: 05-MON-68
EA: 05-44800K

County	Route	Location Post Mile (PM)	Location KiloPost (KP)	Water Quality Volume (Cubic Meters)
--------	-------	----------------------------	---------------------------	---

This treatment will be looked at at PS&E phase

Biofiltration Swales

District-County-Route: 05-MON-68
EA: 05-44800K

County	Route	From Location Post Mile (PM)	To Location Post Mile (PM)	From Location KiloPost (KP)	To Location Post Mile (KP)
--------	-------	---------------------------------	-------------------------------	--------------------------------	-------------------------------

This treatment will be looked at at PS&E phase

Construction Site BMP Consideration Form

DATE: 05-02-08

Project Evaluation Process for the Consideration of Construction Site BMPs

EA: 448000

NO.	CRITERIA	YES	NO	SUPPLEMENTAL INFORMATION
1.	Will construction of the project result in areas of disturbed soil as defined by the Project Planning and Design Guide (PPDG)?	<input checked="" type="checkbox"/>	<input type="checkbox"/>	If Yes , Construction Site BMPs for Soil Stabilization (SS) will be required. Complete CS-1, Part 1. Continue to 2. If No , Continue to 3.
2.	Is there a potential for disturbed soil areas within the project to discharge to storm drain inlets, drainage ditches, areas outside the right of way, etc?	<input checked="" type="checkbox"/>	<input type="checkbox"/>	If Yes , Construction Site BMPs for Sediment Control (SC) will be required. Complete CS-1, Part 2. Continue to 3.
3.	Is there a potential for sediment or construction related materials and wastes to be tracked offsite and deposited on private or public paved roads by construction vehicles and equipment?	<input checked="" type="checkbox"/>	<input type="checkbox"/>	If Yes , Construction Site BMPs for Tracking Control (TC) will be required. Complete CS-1, Part 3. Continue to 4.
4.	Is there a potential for wind to transport soil and dust offsite during the period of construction?	<input checked="" type="checkbox"/>	<input type="checkbox"/>	If Yes , Construction Site BMPs for Wind Erosion Control (WE) will be required. Complete CS-1, Part 4. Continue to 5.
5.	Is dewatering anticipated or will construction activities occur within or adjacent to a live channel or stream?	<input type="checkbox"/>	<input checked="" type="checkbox"/>	If Yes , Construction Site BMPs for Non-Storm Water Management (NS) will be required. Complete CS-1, Part 5. Continue to 6.
6.	Will construction include saw-cutting, grinding, drilling, concrete or mortar mixing, hydro-demolition, blasting, sandblasting, painting, paving, or other activities that produce residues?	<input checked="" type="checkbox"/>	<input type="checkbox"/>	If Yes , Construction Site BMPs for Non-Storm Water Management (NS) will be required. Complete CS-1, Part 5. Continue to 7.
7.	Are stockpiles of soil, construction related materials, and/or wastes anticipated?	<input checked="" type="checkbox"/>	<input type="checkbox"/>	If Yes , Construction Site BMPs for Waste Management and Materials Pollution Control (WM) will be required. Complete CS-1, Part 6. Continue to 8.
8.	Is there a potential for construction related materials and wastes to have direct contact with precipitation; storm water run-on, or stormwater runoff; be dispersed by wind; be dumped and/or spilled into storm drain systems?	<input checked="" type="checkbox"/>	<input type="checkbox"/>	If Yes , Construction Site BMPs for Waste Management and Materials Pollution Control (WM) will be required. Complete CS-1, Part 6. Continue to 9.
9.	End of checklist.	<input checked="" type="checkbox"/>		Document for Project Files by completing this form, and attaching it to the SWDR.

PE to initialize after concurrence with Construction (PS&E only)

Date



ATTACHMENT A
LOCATION MAP

*Route 68 /Holman Highway
In the County of Monterey
MON-05-68
KP 6.1/L6.9 (PM 3.8/L4.3)*

LOCATION MAP



Mark Thomas & Company, Inc.
ENGINEERS - PLANNERS - SURVEYORS

ATTACHMENT B
PROJECT GEOMETRICS



- LEGEND**
- RETAINING WALL
 - GUARD RAIL
 - CONCRETE BARRIER
 - EXISTING ACCESS CONTROL
 - PROPOSED ACCESS CONTROL
 - EXISTING R/W
 - PROPOSED R/W

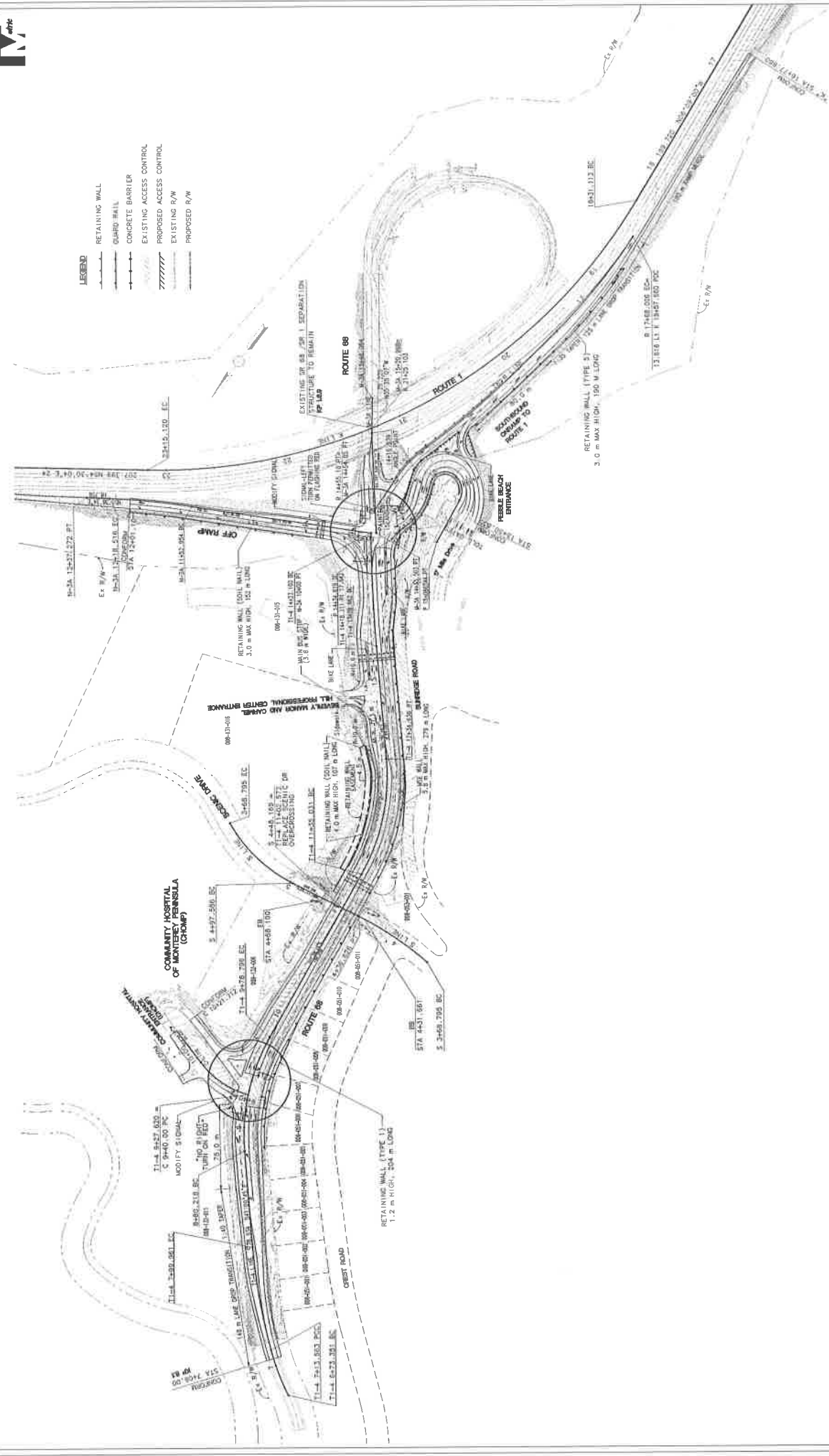

O5-MON-68-KP 6:1/L6.9 (PM 3.8/L4.3)
 PDT PREFERRED ALTERNATIVE 3A
 EA - 448000



GRAPHIC SCALE
 (IN FEET)

FIGURE 1-3 GEOMETRICS OF THE PROJECT

ATTACHMENT C
TYPICAL SECTIONS

DIST COUNTY ROUTE TOTAL PROJECT SHEET NO. OF SHEETS
 05 MON 68 5.1/6.9

REGISTERED CIVIL ENGINEER
 P.L. TAMMA
 No. 23233
 Exp. 12/31/09
 CIVIL

CITY OF MONTEREY
 PUBLIC WORK DEPARTMENT
 MONTEREY, CA 95940

MARK THOMAS & CO. INC.
 1960 ZANKER ROAD
 SAN JOSE, CA 95112

The State of California or its officers or agents shall not be responsible for the accuracy or completeness of electronic copies of this plan sheet.



DATE REVISION BY
 CHECKED BY
 CALCULATED BY
 DESIGN OVERSIGHT

STATE OF CALIFORNIA - DEPARTMENT OF TRANSPORTATION

ALL DIMENSIONS ARE IN METERS UNLESS OTHERWISE SHOWN.

FOR REDUCED PLANS ORIGINAL SCALE IS IN MILLIMETERS

FORM 07-06-02-04 (REV. 2/00)

X

X

X

X

X

X

X

X

X

X

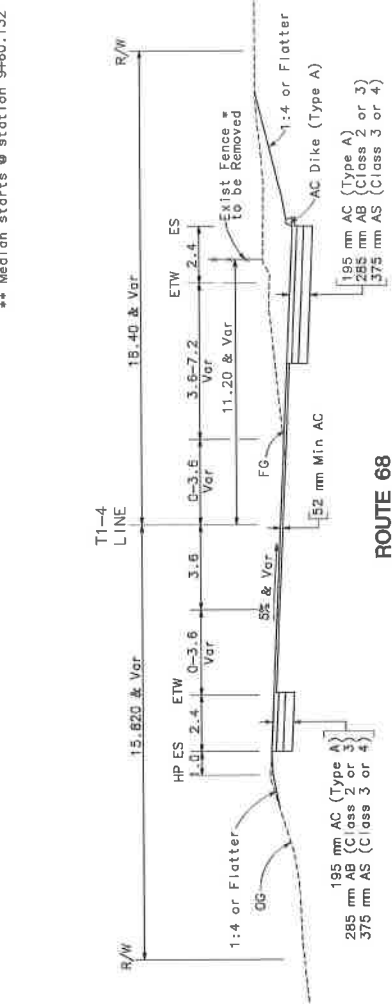
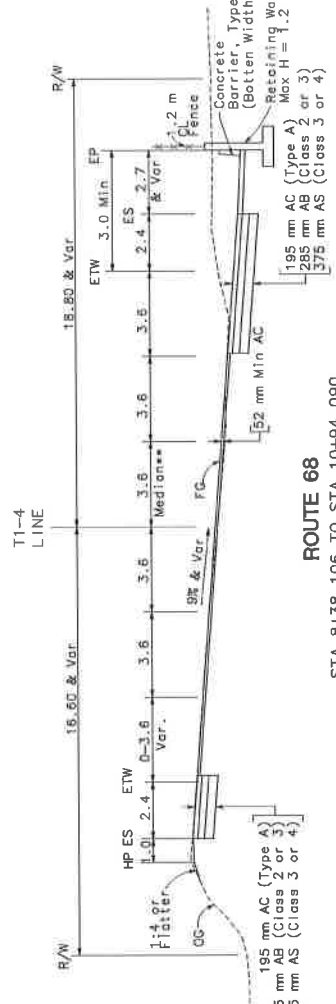
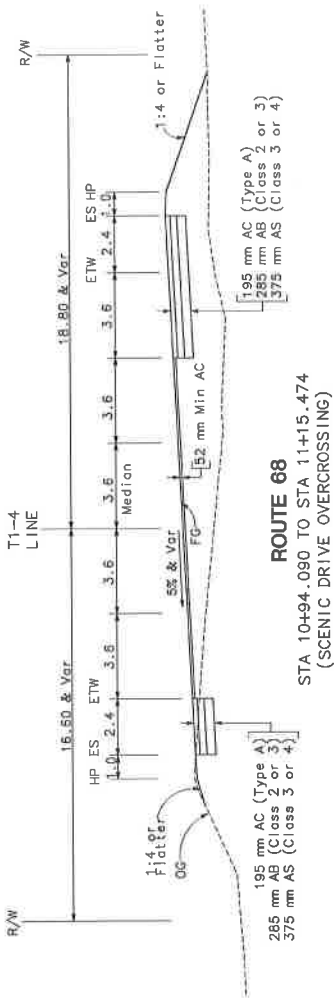

ALL DIMENSIONS ARE IN METERS UNLESS OTHERWISE SHOWN.

TYPICAL CROSS SECTIONS
 NO SCALE

X-1

EA

CU



ALL DIMENSIONS ARE IN METERS UNLESS OTHERWISE SHOWN.

* Fence starts @ station 8+15.082

* Retaining Wall starts @ station 8+80.216
 ** Median starts @ station 9+60.132



DIST	COUNTY	ROUTE	MILEAGE POST MILES TOTAL PROJECT
05	MON	58	6.1/16.9

REGISTERED CIVIL ENGINEER
 PLUMB APPROVAL DATE
 CITY OF MONTEREY
 PUBLIC WORK DEPARTMENT
 MONTEREY, CA 93940

MARK THOMAS & CO. INC.
 1960 ZANKER ROAD
 SAN JOSE, CA 95112

The State of California or its officers or agents shall not be responsible for any errors or omissions or consequences of electronic copy of this plan sheet.



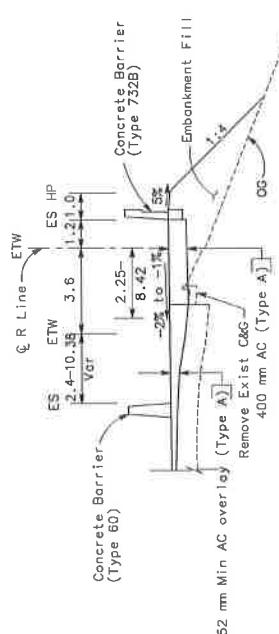

SB ROUTE 1 ON RAMP
 STA. 13492.055 TO 14461.433

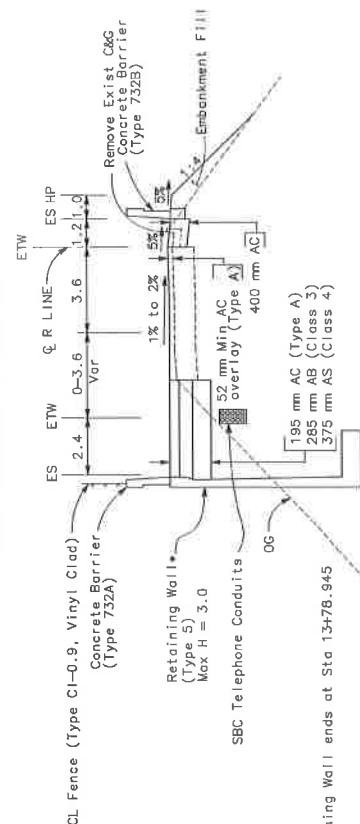

SB ROUTE 1 ON RAMP
 STA. 13437.062 TO 13492.055

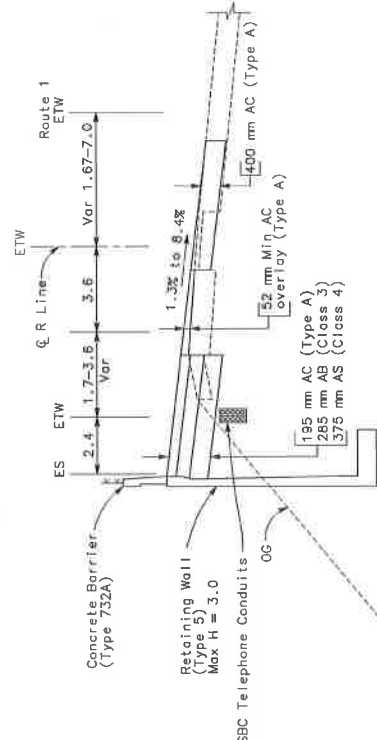

SB ROUTE 1 ON RAMP
 STA. 12+52.657 TO 13+37.062

Concrete Barrier (Type 60)

ES HP 1.211.0

ES 2.4-10.35 Var 3.6

ETW 2.25-8.42

Concrete Barrier (Type 732B)

Embankment Fill

OG

52 mm Min AC overlay (Type A)

Remove Exist C&G 400 mm AC (Type A)

CL Fence (Type CI-0.9, Vinyl Clad)

Concrete Barrier (Type 732A)

Retaining Wall (Type 5) Max H = 3.0

SBC Telephone Conduits

OG

195 mm AC (Type A)

285 mm AS (Class 3)

375 mm AS (Class 4)

52 mm Min AC overlay (Type A)

400 mm AC

Remove Exist C&G Concrete Barrier (Type 732B)

Embankment Fill

OG

1% to 2%

Route 1 ETW

ES HP 1.67-7.0

ES 2.4-1.7-3.6 Var 1.67-7.0

ETW 1.7-3.6

Concrete Barrier (Type 732A)

Retaining Wall (Type 5) Max H = 3.0

SBC Telephone Conduits

OG

195 mm AC (Type A)

285 mm AS (Class 3)

375 mm AS (Class 4)

52 mm Min AC overlay (Type A)

400 mm AC (Type A)

1.3% to 0.4%

* Retaining Wall ends at Sta 13+78.945

ALL DIMENSIONS ARE IN METERS UNLESS OTHERWISE SHOWN.

FOR REDUCED PLANS
 ORIGINAL SCALE IS IN MILLIMETERS



FORM DC-05-02-PF (REV. 3/89)

EA

CU

EA

X-5

DIST	COUNTY	ROUTE	TOTAL PROJECT SHEET NO.	SHEET NO.
05	MON	6B	6.1/L6.9	



REGISTERED CIVIL ENGINEER
 PLANS APPROVAL DATE
 CITY OF MONTEREY
 PUBLIC WORK DEPARTMENT
 MONTEREY, CA 93940
 MARK THOMAS & CO. INC.
 1960 ZANKER ROAD
 SAN JOSE, CA 95112

The State of California, for the purpose of this plan, shall not be responsible for the accuracy or completeness of electronic copies of this plan sheet.

DATE	REVISD BY	DESIGNED BY	CHECKED BY

DESIGN OVERSIGHT

STATE OF CALIFORNIA - DEPARTMENT OF TRANSPORTATION



ALL DIMENSIONS ARE IN METERS UNLESS OTHERWISE SHOWN.

FORM CC-25-25-25-25 (REV. 2/02)

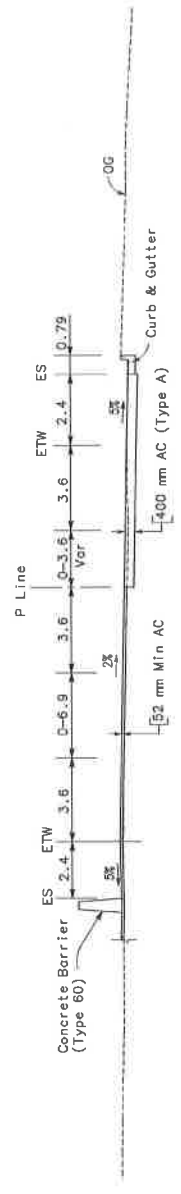
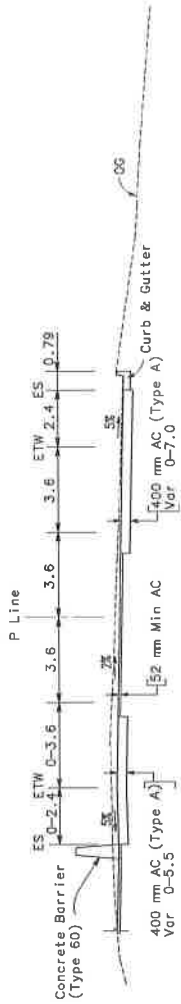
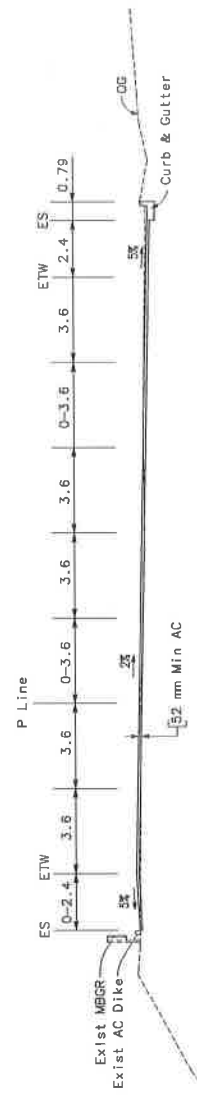

ALL DIMENSIONS ARE IN METERS UNLESS OTHERWISE SHOWN.

TYPICAL CROSS SECTIONS
 NO SCALE

X-6



EA

ATTACHMENT D

**RAINFALL INTENSITY
DURATION/FREQUENCY DATA SHEET**

GENERAL INFORMATION:

Input by: BN
 Input Date: 10/7/2020
 Project Description: Highway 68 KP6.1 (PM 3.8)

SITE DATA

Latitude: 36.34 deg.
 Longitude: 121.54 deg.
 Return Period: 25 years

SELECTED STATIONS

Station Name	Station ID	Elev. ft	Lat. deg.	Long. deg.	Dist. miles
ARROYO SECO	D200322000	800	36.2330	121.4830	8.05
SOLEDAD	D208338000	204	36.4330	121.3170	13.97
MT TORO	D205998080	2370	36.5500	121.6330	15.41
LAURELES GRADE	D204836050	1350	36.5500	121.7500	18.63

COMPUTED INTENSITIES (INCHES/HOUR)

Return Period	25-yr	2-yr	10-yr	25-yr	50-yr	100-yr	10,000-yr
Duration							
5-min	2.411	1.209	2.013	2.423	2.695	2.985	4.702
10-min	1.791	0.898	1.495	1.800	2.002	2.217	3.493
15-min	1.505	0.755	1.256	1.513	1.682	1.863	2.935
30-min	1.118	0.561	0.933	1.124	1.250	1.384	2.181
60-min	0.831	0.417	0.693	0.835	0.928	1.028	1.620
120-min	0.617	0.310	0.515	0.620	0.690	0.764	1.203
4-hr	0.458	0.230	0.383	0.461	0.512	0.568	0.894
8-hr	0.341	0.171	0.284	0.342	0.381	0.422	0.664
16-hr	0.253	0.127	0.211	0.254	0.283	0.313	0.493
24-hr	0.213	0.107	0.177	0.214	0.238	0.263	0.415

OUTPUT COEFFICIENTS

a = 0.8308
 b = -0.4288

COMPUTED INTENSITIES (MM/HOUR)

Return Period	25-yr	2-yr	10-yr	25-yr	50-yr	100-yr	10,000-yr
Duration							
5-min	61.239	30.709	51.130	61.544	68.453	75.819	119.431
10-min	45.491	22.809	37.973	45.720	50.851	56.312	88.722
15-min	38.227	19.177	31.902	38.430	42.723	47.320	74.549
30-min	28.397	14.249	23.698	28.550	31.750	35.154	55.397
60-min	21.107	10.592	17.602	21.209	23.571	26.111	41.148
120-min	15.672	7.874	13.081	15.748	17.526	19.406	30.556
4-hr	11.633	5.842	9.728	11.709	13.005	14.427	22.708
8-hr	8.661	4.343	7.214	8.687	9.677	10.719	16.866
16-hr	6.426	3.226	5.359	6.452	7.188	7.950	12.522
24-hr	5.410	2.718	4.496	5.436	6.045	6.680	10.541

ATTACHMENT E
SOIL DISTURBED AREA EXHIBIT

STATE OF CALIFORNIA - DEPARTMENT OF TRANSPORTATION	DESIGN OVERSIGHT	CALCULATED / DESIGNED BY	DATE	REVISED BY					
		CHECKED BY		DATE REVISED					

ALL DIMENSIONS ARE IN METERS UNLESS OTHERWISE SHOWN.

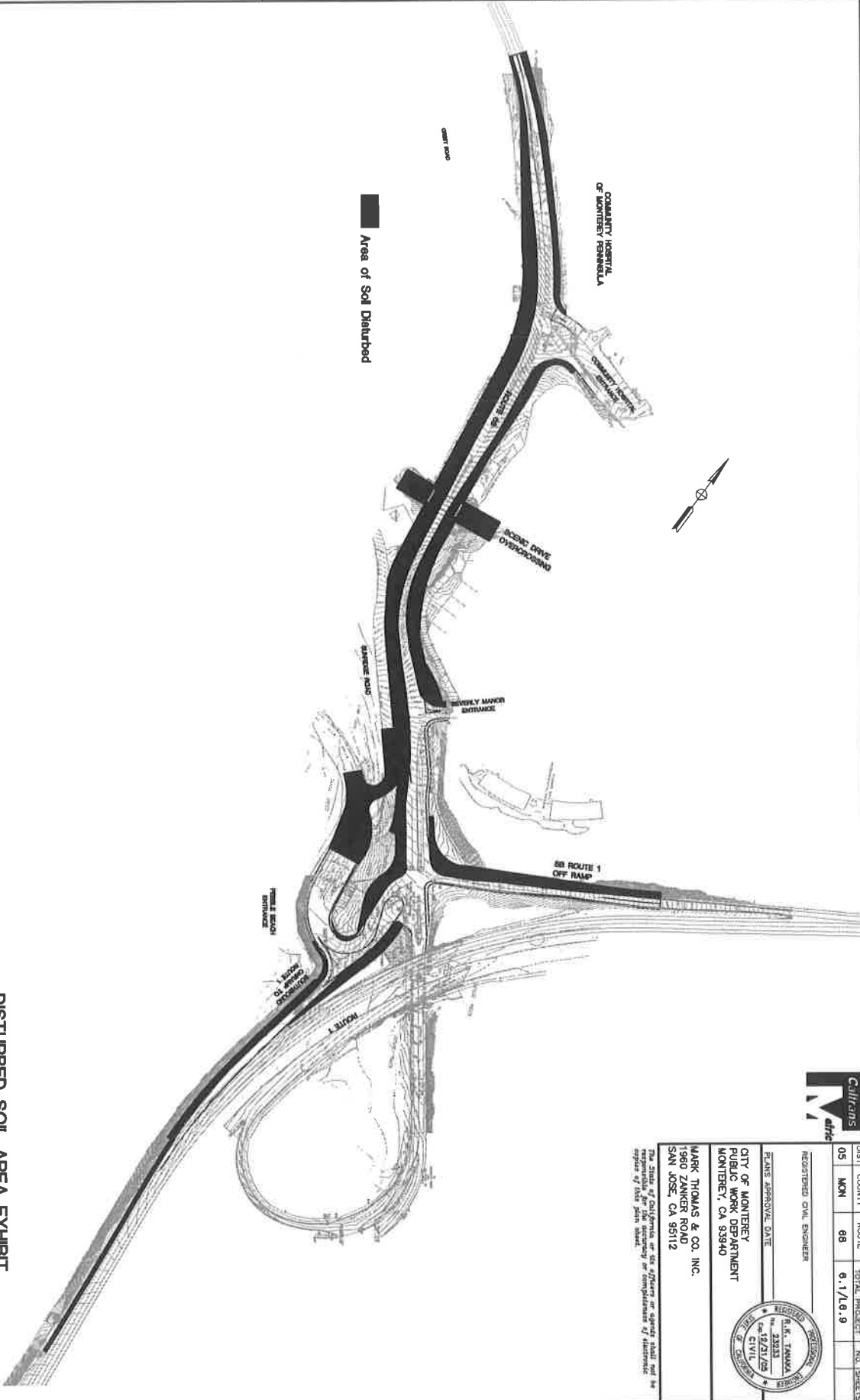

DISTURBED SOIL AREA EXHIBIT

NO SCALE

CU EA



DIS1	COUNTY	ROUTE	ROUTE PER POST SIGNATURES
05	MON	98	6.1/18.9
REGISTERED CIVIL ENGINEER			
PLANS APPROVAL DATE			
CITY OF MONTEREY			
PUBLIC WORK DEPARTMENT			
MONTEREY, CA 95940			
MARK THOMAS & CO. INC.			
1980 ZANKER ROAD			
SAN JOSE, CA 95112			



The State of California or its officers or agents shall not be responsible for the accuracy or completeness of data furnished by the contractor.

SUPPLEMENTAL ATTACHMENTS

- **Storm Water BMP Cost Summary (In Progress)**
- **Project Report Cost Estimate**
- **Checklist SW-1, Site Data Resources**
- **Checklist SW-2, Storm Water Quality Issues Summary**
- **Checklist SW-3, Measures for Avoiding or Reducing Potential Storm Water BMPs**
- **Checklists, DPP-1, Part 1-5 (Design Pollution Prevention BMPs)**
- **Checklists, T-1 Through Part 10 (Treatment BMPs)**
- **Checklists, CS**

PROJECT REPORT COST ESTIMATE SUMMARY

<u>DIST - CO - RTE</u>	<u>05-MON-68</u>
Type of Estimate (Pre-PSR, PSR, PR, etc.):	
	<u>PR</u>
Program Code:	<u>20.xx.075.600 RIP</u>
KP:	<u>6.1/L6.9</u>
EA:	<u>448000</u>
PP No. :	<u> </u>

Project Description:

**Limits: Widening of Route 68 from Community Hospital of Monterey Peninsula (CHOMP)
to Route 1 Interchange in Monterey in Monterey County
FOUR-LANE FIVE LEGGED ULTIMATE FACILITY**

**Proposed Improvement: Widening of Route 68, Modify Signal, Replace 17 Mile Scenic Drive
(Scope) Overcrossing Bridge, Construction of Retaining Wall, MSE Wall and
Living Wall (Sound Wall)**

PROPOSED ALTERNATIVE

(1) Preliminary Engineering/Environmental Phase	\$1,294,000
(2) Final Design (10% of Construction)	\$1,561,000
(3) Construction Support	\$1,247,000
(4) RIGHT OF WAY & UTILITY	\$227,000
(5) CONSTRUCTION PHASE	
ROADWAY ITEMS	\$9,176,000
STRUCTURE ITEMS	\$6,431,000
 SUBTOTAL CONSTRUCTION PHASE	 \$15,607,000
TOTAL ALTERNATIVE COST	 \$ 19,936,000

Reviewed by		<u>10/04/07</u>
Project Engineer	<u>BEN NGUYEN</u>	
Approved by	<u>(408) 453-5373</u>	<u>10/04/07</u>
Project Manager	<u>Richard K. Tanaka</u> (Phone)	<u>(Date)</u>

PROJECT REPORT COST ESTIMATE SUMMARY

DIST - CO - RTE
05-MON-68
 KP: 6.1/L6.9
 EA: 448000
 PP No. : 0

	<u>Quantity</u>	<u>Unit</u>	<u>Unit Price</u>	<u>Unit Cost</u>	<u>Section Cost</u>
<u>Section 1 - Earthwork</u>					
Imported Borrow (Ramp)	1,300	m ³	\$51	\$66,000	
Roadway Excavation	10,000	m ³	\$56	\$560,000	
Clearing & Grubbing	1	LS	\$280,900	\$300,000	
Clearing & Grubbing (Ramp)1	1	LS	\$28,100	\$30,000	
Develop Water Supply		LS		\$0	
				Total Earthwork	\$956,000
<u>Section 2 - Structural Section *</u>					
Pavement(Roadway)	7,400	m ²	\$112	\$829,000	
Pavement(Bikepath)		m ²		\$0	
Pavement(Ramp)	2,626	m ²	\$112	\$294,000	
Overlay	16,900	m ²	\$40	\$676,000	
Remove Pavement	800	m ²	\$34	\$27,000	
Pavement(Throwaway)		m ²		\$0	
Overlay(Throwaway)		m ²		\$0	
Concrete Curb & Gutter		m		\$0	
Aggregate Base		m ³		\$0	
Aggregate Subbase		m ³		\$0	
Permeable Material				\$0	
Blanket & Edge Drains		m		\$0	
Remove & Replace Berm	750	m	\$70	\$53,000	
Concrete Median		m ²		\$0	
				Total Structural Section	\$1,879,000
<u>Section 3 - Drainage</u>					
Box Culvert		m ²		\$0	
Project Drainage	1	LS	\$281,000	\$281,000	
Project Drainage (Ramp)	1	LS	\$56,200	\$56,200	
Pump Station		EA		\$0	
				Total Drainage	\$337,200

* Attach sketch showing typical structural section elements of the roadway.
 include (if available) T.I., R-Value, and date when tests were performed

PROJECT REPORT COST ESTIMATE SUMMARY

DIST - CO - RTE
05-MON-68
 KP: 6.1/L6.9
 EA: 448000
 PP No. : 0

	<u>Quantity</u>	<u>Unit</u>	<u>Unit Price</u>	<u>Unit Cost</u>	<u>Section Cost</u>
<u>Section 4 - Specialty Items</u>					
Ret Walls-Soil Nails		m ²			
Ret Walls Standard (EB)		m ²			
Ret Walls-Standard (Off ramp)		m ²			
Ret Wall-Standard (EB)		m ²			
Ret Wall-Standard (Onramp)		m ²			
Living Wall		m ²			
Median Treatment		m ²			
Median Curb		m ²			
Landscaping/Irrigation					
(normally separate project)	1	LS	\$337,000	\$337,000	
Erosion Control		LS			
Slope Paving		m ³		\$0	
Concrete Barriers	474	m	\$300	\$142,000	
Environmental Mitigation	1	LS	\$168,500	\$169,000	
Remove & Replace Curb	880	m	\$120	\$106,000	
Guardrails	420	m	\$200	\$84,000	
Relocate Freeway Sign	1	LS	\$34,000	\$34,000	
W/PPP/Erosion Control	1	LS	\$300,000	\$300,000	
					<u>Total Specialty Items</u>
					<u>\$1,172,000</u>
<u>Section 5 - Traffic Items</u>					
Lighting	1	LS	\$84,300	\$84,000	
Traffic Signals					
Signal Modification	1	LS	\$450,000	\$450,000	
Permanent Signing	1	LS	\$100,000	\$100,000	
Traffic Control Systems	1	LS	\$300,000	\$300,000	
Traffic Control Systems (Ramp)	1	LS	\$80,000	\$80,000	
Pavement Delineation	1	LS	\$40,000	\$40,000	
Traffic Management Plan	1	LS	\$200,000	\$200,000	
Crash Cushions (Ramp)	1	EA	\$8,400	\$8,000	
Temporary K-rail	2,000	m	\$60	\$120,000	
Temporary K-rail (Ramp)	450	m	\$60	\$27,000	
Ramp Meters		EA		\$0	
					<u>Total Traffic Items</u>
					<u>\$1,409,000</u>
					<u>SUBTOTAL SECTIONS 1 - 5:</u>
					<u>\$5,753,000</u>

PROJECT REPORT COST ESTIMATE SUMMARY

	<u>DIST - CO - RTE</u>
	<u>05-MON-68</u>
KP:	<u>6.1/L6.9</u>
EA:	<u>448000</u>
PP No. :	<u>0</u>

		<u>Unit Cost</u>	<u>Section Cost</u>
Section 6 - Minor Items			
Subtotal Sections 1 - 5	\$5,753,000 X	10%	\$575,300
			TOTAL MINOR ITEMS: <u>\$575,000</u>
Section 7 - Roadway Mobilization			
Subtotal Sections 1 - 5	\$5,753,000		
Minor Items	\$575,000		
Sum	\$6,328,000 X	10%	\$632,800
			TOTAL ROADWAY MOBILIZATION <u>\$633,000</u>
Section 8 - Roadway Additions			
Supplemental			
Subtotal Sections 1 - 5	\$5,753,000		
Minor Items	\$575,000		
Sum	\$6,328,000 X	10%	\$632,800
Contingencies			
Subtotal Sections 1 - 5	\$5,753,000		
Minor Items	\$575,000		
Sum	\$6,328,000 X	25%	\$1,582,000
			TOTAL ROADWAY ADDITIONS <u>\$2,215,000</u>
			TOTAL ROADWAY ITEMS <u>\$9,176,000</u>
(Total of Sections 1 - 8)			

Estimate Prepared By:	BEN NGUYEN	(408) 453-5373	10/04/07
	(Print Name)	(Phone)	(Date)

PROJECT REPORT COST ESTIMATE SUMMARY

DIST - CO - RTE
05-MON-68
 KP: 6.1/L6.9
 EA: 448000
 PP No. : 0

II. STRUCTURES ITEMS

	#1	#2	#3
Bridge Name	Scenic Drive Overpass		
Structure Type	New Precast Concrete		
Width (m) - out to out	13		
Span Length (m)	37		
Total Area (m ²)	466		
Footing Type (pile/spread)			
Cost per Sq. Meter Including: Mobilization: 10% Contingency: 25%	\$2,200		
Bridge Removal	\$245,000		
Total Cost For Structure	\$1,271,000		

Total Bridge Item \$1,271,000

SPECIALTY RETAINING WALL

	Unit	Quantity	Unit Price	Unit Cost
Retaining Wall (Type 1)	m ²	250	\$1,200	\$300,000
Retaining Wall (Soil Nail)	m ²	1400	\$1,800	\$2,520,000
Retaining Wall (MSE Wall)	m ²	1620	\$1,000	\$1,620,000
Retaining Wall (Type 5)	m ²	600	\$1,200	\$720,000

Cost per Sq. Meter Including: Total Specialty Item \$5,160,000
 Aesthetics: 10%
 Contingency: 25% **TOTAL STRUCTURES ITEMS** \$6,431,000

Estimate Prepared By: BEN NGUYEN (408) 453-5373 10/04/07
(Print Name) (Phone) (Date)

PROJECT REPORT COST ESTIMATE SUMMARY

	<u>DIST - CO - RTE</u>
	<u>05-MON-68</u>
KP:	<u>6.1/L6.9</u>
EA:	<u>448000</u>
PP No. :	<u>0</u>

III. RIGHT OF WAY

Right-of-Way estimates should consider the probable highest and best use and type and intent of improvements at the time of acquisition. Assume acquisition including utility relocation occurs at the right of way certification milestone as shown in the Funding and Scheduling Section of the PSR. For further guidance see Chapter 1, Caltrans Right of Way Procedural Handbook.

	Current Values	Escalation Rate (%/yr)	Escalated Value *
Acquisition, including excess lands and damages to remainders	\$103,000	5.00%	\$129,000
Utility Relocation (State Share)	\$95,000		\$95,000
Clearance / Demolition			\$0
RAP			\$0
R/W Services - Title and Escrow Fees			\$3,000
CONSTRUCTION CONTRACT WORK			\$0
Permanent Easement		5.00%	\$0
TOTAL RIGHT OF WAY ** (CURRENT VALUE)	\$198,000	TOTAL ESCALATED RIGHT OF WAY	\$227,000

* - Escalated to assumed year of advertising:

** - Current total value for use on sheet 1 of 6

Beverly Manor R/W Take: 681 m2 @ \$150 = \$102,150

Beverly Manor Easements: 480 m2 @ \$55 = \$26,400

Estimate prepared by: BEN NGUYEN (408) 453-5373 10/04/07

Storm Water Checklist SW-1

Checklist SW-1, Site Data Sources

Prepared by: BN Date: 05-02-08 District-Co-Route: 05-MON-68
 PM (KP): 6.1/L6.9(3.8/L4.3) EA: 448000
 RWQCB: REGION 3 CENTRAL COAST

Information for the following data categories should be obtained, reviewed and referenced as necessary throughout the project planning phase. Collect any available documents pertaining to the category and list them and reference your data source. For specific examples of documents within these categories, refer to Section 5.5 of this document. Example categories have been listed below; add additional categories, as needed. Summarize pertinent information in Section 2 of the SWDR.

DATA CATEGORY/SOURCES	Date
Topographic	
• Aerial Planimetric Mapping	Currently available
• Field Topographic Survey (Trees) – Mark Thomas & Company, Inc.	Currently available
• USGS Map	
Hydraulic	
• Drainage Report	In progress
•	
•	
Soils	
• Geotechnical Design Report (Parikh Consultants)	In Progress
•	
•	
Climatic	
• Rain IDF Curve	Currently available
•	
•	
Water Quality	
• Environmental Impact Report (CEQA) and Environmental Assessment (NEPA) (By PAR Environmental Services, Inc)	In Progress
•	
•	
Other Data Categories	
•	
•	
•	
•	
•	
•	

Checklist SW-2, Storm Water Quality Issues Summary			
Prepared by: <u>BN</u>	Date: <u>05-02-08</u>	District-Co-Route: <u>05-MON-68</u>	
PM (KP): <u>6.1/L6.9(3.8/L4.3)</u>	EA: <u>448000</u>		
RWQCB: <u>REGION 3 CENTRAL COAST</u>			

The following questions provide a guide to collecting critical information relevant to project stormwater quality issues. Complete responses to applicable questions, consulting other Caltrans functional units (Environmental, Landscape Architecture, Maintenance, etc.) and the District/Regional Storm Water Coordinator as necessary. Summarize pertinent responses in Section 2 of the SWDR.

- | | | |
|--|--|--|
| 1. Determine the receiving waters that may be affected by the project throughout the project life cycle (i.e., construction, maintenance and operation). | <input checked="" type="checkbox"/> Complete | <input type="checkbox"/> NA |
| 2. For the project limits, list the 303(d) impaired receiving water bodies and their constituents of concern. | <input type="checkbox"/> Complete | <input checked="" type="checkbox"/> NA |
| 3. Determine if there are any municipal or domestic water supply reservoirs or groundwater percolation facilities within the project limits. Consider appropriate spill contamination and spill prevention control measures for these new areas. | <input type="checkbox"/> Complete | <input checked="" type="checkbox"/> NA |
| 4. Determine the RWQCB special requirements, including TMDLs, effluent limits, etc. | <input checked="" type="checkbox"/> Complete | <input type="checkbox"/> NA |
| 5. Determine regulatory agencies seasonal construction and construction exclusion dates or restrictions required by federal, state, or local agencies. | <input checked="" type="checkbox"/> Complete | <input type="checkbox"/> NA |
| 6. Determine if a 401 certification will be required. | <input checked="" type="checkbox"/> Complete | <input type="checkbox"/> NA |
| 7. List rainy season dates. (Oct 15 thru April 15) | <input checked="" type="checkbox"/> Complete | <input type="checkbox"/> NA |
| 8. Determine the general climate of the project area. Identify annual rainfall and rainfall intensity curves. | <input checked="" type="checkbox"/> Complete | <input type="checkbox"/> NA |
| 9. If considering Treatment BMPs, determine the soil classification, permeability, erodibility, and depth to groundwater. | <input checked="" type="checkbox"/> Complete | <input type="checkbox"/> NA |
| 10. Determine contaminated or hazardous soils within the project area. | <input checked="" type="checkbox"/> Complete | <input type="checkbox"/> NA |
| 11. Determine the total disturbed soil area of the project. | <input checked="" type="checkbox"/> Complete | <input type="checkbox"/> NA |
| 12. Describe the topography of the project site. | <input checked="" type="checkbox"/> Complete | <input type="checkbox"/> NA |
| 13. List any areas outside of the Caltrans right-of-way that will be included in the project (e.g. contractor's staging yard, work from barges, easements for staging, etc.). | <input checked="" type="checkbox"/> Complete | <input type="checkbox"/> NA |
| 14. Determine if additional right-of-way acquisition or easements and right-of-entry will be required for design, construction and maintenance of BMPs. If so, how much? | <input checked="" type="checkbox"/> Complete | <input type="checkbox"/> NA |
| 15. Determine if a right-of-way certification is required. | <input checked="" type="checkbox"/> Complete | <input type="checkbox"/> NA |
| 16. Determine the estimated unit costs for right-of-way should it be needed for Treatment BMPs, stabilized conveyance systems, lay-back slopes, or interception ditches. | <input checked="" type="checkbox"/> Complete | <input type="checkbox"/> NA |
| 17. Determine if project area has any slope stabilization concerns. | <input checked="" type="checkbox"/> Complete | <input type="checkbox"/> NA |
| 18. Describe the local land use within the project area and adjacent areas. | <input checked="" type="checkbox"/> Complete | <input type="checkbox"/> NA |
| 19. Evaluate the presence of dry weather flow. | <input checked="" type="checkbox"/> Complete | <input type="checkbox"/> NA |

Checklist SW-3, Measures for Avoiding or Reducing Potential Storm Water Impacts

Prepared by: BN Date: 05-02-08 District-Co-Route: 05-MON-68
 PM (KP): 6.1/L6.9(3.8/L4.3) EA: 448000
 RWQCB: REGION 3 CENTRAL COAST

The PE must confer with other functional units, such as Landscape Architecture, Hydraulics, Environmental, Materials, Construction and Maintenance, as needed to assess these issues. Summarize pertinent responses in Section 2 of the SWDR.

Options for avoiding or reducing potential impacts during project planning include the following:

1. Can the project be relocated or realigned to avoid/reduce impacts to receiving waters or to increase the preservation of critical (or problematic) areas such as floodplains, steep slopes, wetlands, and areas with erosive or unstable soil conditions? Yes No NA
2. Can structures and bridges be designed or located to reduce work in live streams and minimize construction impacts? Yes No NA
3. Can any of the following methods be utilized to minimize erosion from slopes:
 - a. Disturbing existing slopes only when necessary? Yes No NA
 - b. Minimizing cut and fill areas to reduce slope lengths? Yes No NA
 - c. Incorporating retaining walls to reduce steepness of slopes or to shorten slopes? Yes No NA
 - d. Acquiring right-of-way easements (such as grading easements) to reduce steepness of slopes? Yes No NA
 - e. Avoiding soils or formations that will be particularly difficult to re-stabilize? Yes No NA
 - f. Providing cut and fill slopes flat enough to allow re-vegetation and limit erosion to pre-construction rates? Yes No NA
 - g. Providing benches or terraces on high cut and fill slopes to reduce concentration of flows? Yes No NA
 - h. Rounding and shaping slopes to reduce concentrated flow? Yes No NA
 - i. Collecting concentrated flows in stabilized drains and channels? Yes No NA
4. Does the project design allow for the ease of maintaining all BMPs? Yes No
5. Can the project be scheduled or phased to minimize soil-disturbing work during the rainy season? Yes No
6. Can permanent storm water pollution controls such as paved slopes, vegetated slopes, basins, and conveyance systems be installed early in the construction process to provide additional protection and to possibly utilize them in addressing construction storm water impacts? Yes No NA



Design Pollution Prevention BMPs		
Checklist DPP-1, Part 1		
Prepared by: <u>BN</u>	Date: <u>05-02-08</u>	District-Co-Route: <u>05-MON-68</u>
PM (KP): <u>6.1/L6.9(3.8/L4.3)</u>	EA: <u>448000</u>	
RWQCB: <u>REGION 3 CENTRAL COAST</u>		

Consideration of Design Pollution Prevention BMPs

1. Consideration of Downstream Effects Related to Potentially Increased Flow [to streams or channels]?

- (a) Will project increase velocity or volume of downstream flow? Yes No NA
- (b) Will the project discharge to unlined channels? Yes No NA
- (c) Will project increase potential sediment load of downstream flow? Yes No NA
- (d) Will project encroach, cross, realign, or cause other hydraulic changes to a stream that may affect downstream channel stability? Yes No NA

If Yes was answered to any of the above questions, consider **Downstream Effects Related to Potentially Increased Flow**, complete the DPP-1, Part 2 checklist.

2. Slope/Surface Protection Systems

- (a) Will project create new slopes or modify existing slopes? Yes No NA

If Yes was answered to the above question, consider **Slope/Surface Protection Systems**, complete the DPP-1, Part 3 checklist.

3. Concentrated Flow Conveyance Systems

- (a) Will the project create or modify ditches, dikes, berms, or swales? Yes No NA
- (b) Will project create new slopes or modify existing slopes? Yes No NA
- (c) Will it be necessary to direct or intercept surface runoff? Yes No NA
- (d) Will cross drains be modified? Yes No NA

If Yes was answered to any of the above questions, consider **Concentrated Flow Conveyance Systems**; complete the DPP-1, Part 4 checklist.

4. Preservation of Existing Vegetation

- a) It is the goal of the Storm Water Program to maximize the protection of desirable existing vegetation to provide erosion and sediment control benefits on all projects. Complete

Consider **Preservation of Existing Vegetation**, complete the DPP-1, Part 5 checklist.



Design Pollution Prevention BMPs

Checklist DPP-1, Part 2

Prepared by: BN Date: 05-02-08 District-Co-Route: 05-MON-68

PM (KP): 6.1/L6.9(3.8/L4.3) EA: 448000

RWQCB: REGION 3 CENTRAL COAST

Downstream Effects Related to Potentially Increased Flow

1. Review total paved area and reduce to the maximum extent practicable. Complete
2. Review channel lining materials and design for stream bank erosion control. Complete
 - (a) See Chapters 860 and 870 of the HDM. Complete
 - (b) Consider channel erosion control measures within the project limits as well as downstream. Consider scour velocity. Complete
3. Include, where appropriate, energy dissipation devices at culvert outlets. Complete
4. Ensure all transitions between culvert outlets/headwalls/wingwalls and channels are smooth to reduce turbulence and scour. Complete
5. Include, if appropriate, peak flow attenuation basins to reduce peak discharges. Complete



Design Pollution Prevention BMPs			
Checklist DPP-1, Part 3			
Prepared by: <u>BN</u>	Date: <u>05-02-08</u>	District-Co-Route: <u>05-MON-68</u>	
PM (KP): <u>6.1/L6.9(3.8/L4.3)</u>	EA: <u>448000</u>		
RWQCB: <u>REGION 3 CENTRAL COAST</u>			

Slope / Surface Protection Systems

- What are the proposed areas of cut and fill? (attach plan or map) Complete
- Were benches or terraces provided on high cut and fill slopes to reduce concentration of flows? Yes No
- Were slopes rounded and/or shaped to reduce concentrated flow? Yes No
- Were concentrated flows collected in stabilized drains or channels? Yes No
- Are slopes > 1:4 vertical:horizontal (V:H)? Yes No
- If Yes, District Landscape Architecture must prepare or approve an erosion control plan.
- Are slopes > 1:2 (V:H)? Yes No
- If Yes, Geotechnical Services must prepare a Geotechnical Design Report, and the District Landscape Architect should prepare or approve an erosion control plan. Concurrence must be obtained from the District Maintenance Storm Water Coordinator for slopes steeper than 1:2 (V:H).
- Estimate the change to the impervious areas that will result from this project. 1.18 ha Complete
(2.92 acres)

VEGETATED SURFACES

1. Identify existing vegetation. Complete
2. Evaluate site to determine soil types, appropriate vegetation and planting strategies. Complete
3. How long will it take for permanent vegetation to establish? Complete
4. Minimize overland and concentrated flow depths and velocities. Complete

HARD SURFACES

1. Are hard surfaces required? Yes No
- If Yes, document purpose (safety, maintenance, soil stabilization, etc.), types, and general locations of the installations. Complete

Review appropriate SSPs for Vegetated Surface and Hard Surface Protection Systems. Complete



Design Pollution Prevention BMPs					
Checklist DPP-1, Part 4					
Prepared by:	BN	Date:	05-02-08	District-Co-Route:	05-MON-68
PM (KP):	6.1/L6.9(3.8/L4.3)	EA:	448000		
RWQCB:	REGION 3 CENTRAL COAST				

Concentrated Flow Conveyance Systems

Ditches, Berms, Dikes and Swales

- 1. Consider Ditches, Berms, Dikes, and Swales as per Chapters 813, 836, and 860 of the HDM. Complete
- 2. Evaluate risks due to erosion, overtopping, flow backups or washout. Complete
- 3. Consider outlet protection where localized scour is anticipated. Complete
- 4. Examine the site for run-on from off-site sources. Complete
- 5. Consider channel lining when velocities exceed scour velocity for soil. Complete

Overside Drains

- 1. Consider downdrains, as per Index 834.4 of the HDM. Complete
- 2. Consider paved spillways for side slopes flatter than 1:4 V:H. Complete

Flared Culvert End Sections

- 1. Consider flared end sections on culvert inlets and outlets as per Chapter 827 of the HDM. Complete

Outlet Protection/Velocity Dissipation Devices

- 1. Consider outlet protection/velocity dissipation devices at outlets, including cross drains, as per Chapters 827 and 870 of the HDM. Complete

Review appropriate SSPs for Concentrated Flow Conveyance Systems. Complete



Design Pollution Prevention BMPs		
Checklist DPP-1, Part 5		
Prepared by: <u>BN</u>	Date: <u>05-02-08</u>	District-Co-Route: <u>05-MON-68</u>
PM (KP): <u>6.1/L6.9(3.8/L4.3)</u>	EA: <u>448000</u>	
RWQCB: <u>REGION 3 CENTRAL COAST</u>		

Preservation of Existing Vegetation

1. Review Preservation of Property, Standard Specifications 16.1.01 and 16-1.02 (Clearing and Grubbing) to reduce clearing and grubbing and maximize preservation of existing vegetation. Complete

2. Has all vegetation to be retained been coordinated with Environmental, and identified and defined in the contract plans? Yes No

3. Have steps been taken to minimize disturbed areas, such as locating temporary roadways to avoid stands of trees and shrubs and to follow existing contours to reduce cutting and filling? Complete

4. Have impacts to preserved vegetation been considered while work is occurring in disturbed areas? Yes No

5. Are all areas to be preserved delineated on the plans? Yes No



Treatment BMPs			
Checklist T-1, Part 1			
Prepared by: <u>BN</u>	Date: <u>05-02-08</u>	District-Co-Route: <u>05-MON-68</u>	
PM (KP): <u>6.1/L6.9(3.8/L4.3)</u>	EA: <u>448000</u>		
RWQCB: <u>REGION 3 CENTRAL COAST</u>			

Consideration of Treatment BMPs

This checklist is used for projects that require the consideration of Approved Treatment BMPs, as determined from the process described in Section 4 (Project Treatment Consideration) and the Evaluation Documentation Form (EDF). This checklist will be used to determine which Treatment BMPs should be considered for each watershed and sub-watersheds within the project. Supplemental data will be needed to verify siting and design applicability for final incorporation into a project.

Complete this checklist for each phase of the project, when considering Treatment BMPs. Use the responses to the questions as the basis when developing the narrative in Section 5 of the Storm Water Data Report to document that Treatment BMPs have been appropriately considered.

Answer all questions, unless otherwise directed.

1. Dry Weather Flow Diversion

- (a) Are dry weather flows generated by Caltrans anticipated to be persistent? Yes No
- (b) Is a sanitary sewer located on or near the site? Yes No
- (c) Is the connection to the sanitary sewer possible without extraordinary plumbing, features or construction practices? Yes No
- (d) Is the domestic wastewater treatment authority willing to accept flow? Yes No

If Yes was answered to all of these questions consider Dry Weather Flow Diversion, complete and attach Part 3 of this checklist

- 2. Is the receiving water on the 303(d) list for litter/trash or has a TMDL been issued for litter/trash? Yes No

If Yes, consider Gross Solids Removal Devices (GSRDs), complete and attach Part 6 of this checklist. Note: Biofiltration Systems, Infiltration Devices, Detention Devices, Media Filters, MCTTs, and Wet Basins also can capture litter – consult with District/Regional NPDES if these devices should be considered to meet litter/trash TMDL.

- 3. Is project located in an area (e.g., mountain regions) where traction sand is applied more than twice a year? Yes No
 If Yes, consider **Traction Sand Traps**, complete and attach **Part 7** of this checklist.



4. (a) Are there local influent limits for infiltration or Basin Plan restrictions or other local agency prohibitions that would restrict the use of the infiltration devices? Yes No

(b) Would infiltration pose a threat to local groundwater quality as determined by the District/Regional Storm Water Coordinator? Yes No

If the answer to either part of Question 4 is Yes, then Infiltration Devices are infeasible and the consideration of Infiltration Devices should not be made when completing Questions 5 through 17.

5. (a) Does the project discharge to any 303(d) listed water body? Yes No
If No, go to Question 17, General Purpose Pollutant Removal

(b) If Yes, is the identified pollutant(s) considered a Targeted Design Constituent (TDC) (check all that apply):

___ phosphorus, ___ nitrogen, ___ total copper, ___ dissolved copper,
___ total lead ___ dissolved lead, ___ total zinc, ___ dissolved zinc,
___ sediments, ___ general metals [unspecified metals].

(c) If no TDC's are checked above, go to Question 17

(d) If only one TDC is checked above, continue to Question 6. Complete

(e) If more than one TDC is checked, contact your District/Regional NPDES Coordinator to determine priority before continuing with this checklist. Complete

6. Consult with the District/Regional Storm Water Coordinator to determine whether Treatment BMP selection will be affected by any existing or future TMDL requirements. Complete

The following questions show the approved Treatment BMPs in order of preference based on load reduction (performance) for the listed constituent and lifetime costs for the device, excluding right-of-way. Note that a line separates Treatment BMPs into groups of approximately equal effectiveness and within each grouping, any of the Treatment BMPs may be selected for placement if meeting site conditions. In the space provided next to the BMP, use Yes or a check mark to indicate a positive response.

If none of the listed Treatment BMPs for a specific constituent of concern (TDC) can be sited, go to Step #17 (General Purpose Pollutant Removal) to determine whether another Treatment BMP can be incorporated into the project.

For the SWDRs developed for the PID and PA/ED phases of a project: Consider all approved Treatment BMPs listed that can be reasonably incorporated into the project for each TDC.

For the SWDR developed for the PS&E phase: Indicate (Yes or check mark) only those BMPs that will be incorporated into the project.



Checklist T-1, Part 1

7. Is phosphorus the TDC? [Use this constituent if "eutrophic" or "nutrients" is the TDC for the water body.] If Yes, consider: Yes No
 Infiltration Devices
 Austin Sand Filters
8. Is nitrogen the TDC? If Yes, consider: Yes No
 Infiltration Devices
 Austin Sand Filters
 Delaware Filter
 Detention Device
 MCTT
9. Is copper (total) the TDC? If Yes for total Copper, consider: Yes No
 Infiltration Devices
 Wet Basins
 Biofiltration Strips
 Detention Device
 Biofiltration Swales
 Austin Sand Filter
 Delaware Filter
 MCTT
10. Is copper (dissolved) the TDC? If Yes for dissolved Copper, consider: Yes No
 Infiltration Devices
 Biofiltration Strips
 Wet Basin
 Biofiltration Swale
11. Is lead (total) the TDC? If Yes for total Lead, consider: Yes No
 Infiltration Devices
 Wet Basin
 Biofiltration Strips
 Austin Sand Filter
 Delaware Filter
 Detention Device
 Biofiltration Swales
 MCTT
12. Is lead (dissolved) the TDC? If Yes for dissolved Lead, consider: Yes No
 Infiltration Devices
 Biofiltration Strips
 Wet Basin
 Detention Device
 Biofiltration Swales
 Austin Sand Filter



13. Is zinc (total) the TDC? If Yes for total Zinc, consider: Yes No
- Infiltration Devices
 - Delaware Filter
 - Wet Basin
 - Biofiltration Strips
 - Biofiltration Swales
 - Austin Sand Filter
 - MCTT
 - Detention Devices
14. Is zinc (dissolved) the TDC? If Yes for dissolved Zinc, consider: Yes No
- Infiltration Devices
 - Delaware Filter
 - Biofiltration Strip
 - Biofiltration Swale
 - Austin Sand Filter
 - MCTT
15. Is sediment (total suspended solids [TSS]) the TDC? If Yes for TSS, consider: Yes No
- Infiltration Devices
 - Austin Sand Filter
 - Delaware Filter
 - Wet Basin
 - Detention Device
 - Biofiltration Strip
 - MCTT
 - Biofiltration Swale
16. Are "General Metals" or (unspecified) "Metals" the TDC? If Yes for General Metals, consider: Yes No
- Infiltration Devices
 - Biofiltration Strips
 - Wet Basin
 - Biofiltration Swale
 - Austin Sand Filter
 - Delaware Filter
 - MCTT
17. General Purpose Pollutant Removal.: When it is determined that there are no TDCs, consider the Treatment BMPs in the order listed below. Yes No
- Infiltration Devices
 - Biofiltration Strips
 - Wet Basin
 - Biofiltration Swale
 - Austin Sand Filter
 - Detention Device
 - Delaware Filter
 - MCTT



Checklist T-1, Part 1

18. Biofiltration Yes No
(a) Are site conditions and climate favorable to allow suitable vegetation to be established?

(b) Have Biofiltration strips and swales been considered to the extent practicable? Note: Biofiltration BMPs should be considered for all projects, even if other Treatment BMPs are placed. Yes No

If No to (a) or (b), document justification in Section 5 of the SWDR.

19. After completing the above, complete and attach the checklists shown below for every Treatment BMP under consideration Complete

- Biofiltration Strips and Biofiltration Swales: Checklist T-1, Part 2
- Dry Weather Diversion: Checklist T-1, Part 3
- Infiltration Devices: Checklist T-1, Part 4
- Detention Devices: Checklist T-1, Part 5
- GSRDs: Checklist T-1, Part 6
- Traction Sand Traps: Checklist T-1, Part 7
- Media Filter [Austin Sand Filter and Delaware Filter]: Checklist T-1, Part 8
- Multi-Chambered Treatment Train: Checklist T-1, Part 9
- Wet Basins: Checklist T-1, Part 10

20. (a) Estimate what percentage of WQV/WQF will be treated by the preferred Treatment BMP(s): _____% Complete

(b) Have Treatment BMPs been considered for use in parallel or series to increase this percentage? Yes No

21. Prepare cost estimate, including right-of-way, for selected Treatment BMPs and include as supplemental information for SWDR approval. Complete



Treatment BMPs			
Checklist T-1, Part 2			
Prepared by: <u>BN</u>	Date: <u>05-02-08</u>	District-Co-Route: <u>05-MON-68</u>	
PM (KP): <u>6.1/L6.9(3.8/L4.3)</u>	EA: <u>448000</u>		
RWQCB: <u>REGION 3 CENTRAL COAST</u>			

Biofiltration Swales / Biofiltration Strips (WILL BE LOOKED AT PS&E PHASE)

Feasibility

1. Do the climate and site conditions allow vegetation to be established? Yes No
2. Are flow velocities < 4 fps (i.e. low enough to prevent scour of the vegetated bioswale as per HDM Table 873.3E)? Yes No

If No to either question above, Biofiltration Swales and Biofiltration Strips are not feasible.
3. Are Biofiltration Swales proposed at sites where known hazardous soils or contaminated groundwater plumes exist? Yes No
If Yes, consult with District/Regional NPDES Coordinator about how to proceed.
4. Does adequate area exist within the right-of-way to place biofiltration device(s)? Yes No
If Yes, continue to the Design Elements section. If No, continue to Question 5.
5. If adequate area does not exist within right-of-way, can suitable, additional right-of-way be acquired to site Biofiltration Devices and how much right-of way would be needed to treat WQF? _____ acres Yes No
If Yes, continue to Design Elements section. If No, continue to Question 6.
6. If adequate area cannot be obtained, document in Section 5 of the SWDR that the inability to obtain adequate area prevents the incorporation of these Treatment BMPs into the project. Complete

Design Elements

* **Required Design Element** – A “Yes” response to these questions is required to further the consideration of this BMP into the project design. Document a “No” response in Section 5 of the SWDR to describe why this Treatment BMP cannot be included into the project design.

** **Recommended Design Element** – A “Yes” response is preferred for these questions, but not required for incorporation into a project design.

1. Has the District Landscape Architect provided vegetation mixes appropriate for climate and location? * Yes No



Checklist T-1, Part 2

2. Can the bioswale be designed as a conveyance system under any expected flows > the WQF event, as per HDM Chapter 800? * (e.g. freeboard, minimum slope, etc.) Yes No
3. Can the bioswale be designed as a water quality treatment device under the WQF while meeting the required HRT, depth, and velocity criteria? (Reference Appendix B, Section B.2.3.1)* Yes No
4. Is the maximum length of a biostrip \leq 300 ft? * Yes No
5. Has the minimum width (in the direction of flow) of the invert of the bioswale received the concurrence of Maintenance? * Yes No
6. Can bioswales be located in natural or low cut sections to reduce maintenance problems caused by animals burrowing through the berm of the swale? ** Yes No
7. Is the biostrip sized as long as possible in the direction of flow? ** Yes No
8. Have Biofiltration Systems been considered for locations upstream of other Treatment BMPs, as part of a treatment train? ** Yes No



Treatment BMPs			
Checklist T-1, Part 3			
Prepared by: <u>BN</u>	Date: <u>05-02-08</u>	District-Co-Route: <u>05-MON-68</u>	
PM (KP): <u>6.1/L6.9(3.8/L4.3)</u>	EA: <u>448000</u>		
RWQCB: <u>REGION 3 CENTRAL COAST</u>			

Dry Weather Flow Diversion (NOT APPLICABLE FOR THIS PROJECT)

Feasibility

1. Is dry-weather flow diversion acceptable to a Publicly Owned Treatment Works (POTW)? Yes No
2. Would a connection require ordinary (i.e., not extraordinary) plumbing, features or construction methods to implement? Yes No
 If No to either question above, Dry Weather Flow Diversion is not feasible.
3. Does adequate area exist within the right-of-way to place Dry Weather Flow Diversion devices? Yes No
 If Yes, continue to Design Elements sections. If No, continue to Question 4.
4. If adequate area does not exist within right-of-way, can suitable, additional right-of-way be acquired to site Dry Weather Flow Diversion devices and how much right-of way would be needed? _____ (acres) Yes No
 If Yes, continue to the Design Elements section.
 If No, continue to Question 5.
5. If adequate area cannot be obtained, document in Section 5 of the SWDR that the inability to obtain adequate area prevents the incorporation of this Treatment BMP into the project. Complete

Design Elements

* **Required Design Element** – A “Yes” response to these questions is required to further the consideration of this BMP into the project design. Document a “No” response in Section 5 of the SWDR to describe why this Treatment BMP cannot be included into the project design.

** **Recommended Design Element** – A “Yes” response is preferred for these questions, but not required for incorporation into a project design.

1. Does the existing sanitary sewer pipeline have adequate capacity to accept project dry weather flows, or can an upgrade be implemented to handle the anticipated dry weather flows within the project's budget and objectives? * Yes No
2. Can the connection be designed to allow for Maintenance vehicle access? * Yes No
3. Can gate, weir, or valve be designed to stop diversion during storm events? * Yes No
4. Can the inlet be designed to reduce chances of clogging the diversion pipe or channel? * Yes No
5. Can a back flow prevention device be designed to prevent sanitary sewage from entering storm drain? * Yes No



Treatment BMPs			
Checklist T-1, Part 4			
Prepared by: <u>BN</u>	Date: <u>05-02-08</u>	District-Co-Route: <u>05-MON-68</u>	
PM (KP): <u>6.1/L6.9(3.8/L4.3)</u>	EA: <u>448000</u>		
RWQCB: <u>REGION 3 CENTRAL COAST</u>			

Infiltration Devices (WILL LOOKED AT PS&E PHASE)

Feasibility

1. Does local Basin Plan or other local ordinance provide influent limits on quality of water that can be infiltrated, and would infiltration pose a threat to groundwater quality as determined by the District/Regional NPDES Storm Water Coordinator? Yes No
2. Does infiltration at the site compromise the integrity of any slopes in the area? Yes No
3. Per survey data or U.S. Geological Survey (USGS) Quad Map, are existing slopes at the proposed device site >15%? Yes No
4. At the invert, does the soil type classify as NRCS Hydrologic Soil Group (HSG) D, or does the soil have an infiltration rate < 0.5 inches/hr? Yes No
5. Is site located over a previously identified contaminated groundwater plume? Yes No
 If Yes to any question above, Infiltration Devices are not feasible; stop here and consider other approved Treatment BMPs.
6. (a) Does site have groundwater within 10 ft of basin invert? Yes No
 (b) Does site investigation indicate that the infiltration rate is significantly greater than 2.5 inches/hr? Yes No
 If Yes to either part of Question 6, the RWQCB must be consulted, and the RWQCB must conclude that the groundwater quality will not be compromised, before approving the site for infiltration. Yes No
7. Does adequate area exist within the right-of-way to place Infiltration Device(s)? Yes No
 If Yes, continue to Design Elements sections. If No, continue to Question 8.
8. If adequate area does not exist within right-of-way, can suitable, additional right-of-way be acquired to site Infiltration Devices and how much right-of way would be needed to treat WQV? _____ acres Yes No
 If Yes, continue to Design Elements section.
 If No, continue to Question 9.
9. If adequate area cannot be obtained, document in Section 5 of the SWDR that the inability to obtain adequate area prevents the incorporation of this Treatment BMP into the project. Complete



Design Elements – Infiltration Basin

* **Required** Design Element – A “Yes” response to these questions is required to further the consideration of this BMP into the project design. Document a “No” response in Section 5 of the SWDR to describe why this Treatment BMP cannot be included into the project design.

** **Recommended** Design Element – A “Yes” response is preferred for these questions, but not required for incorporation into a project design.

1. Has a detailed investigation been conducted, including subsurface soil investigation, in-hole conductivity testing and groundwater elevation determination? (This report must be completed for PS&E level design.) * Yes No
2. Has an overflow spillway with scour protection been provided? * Yes No
3. Is the Infiltration Basin size sufficient to capture the WQV while maintaining a 40-48 hour drawdown time? (Note: the WQV must be $\geq 4,356 \text{ ft}^3$ [0.1 acre-feet]) * Yes No
4. Can access be placed to the invert of the Infiltration Basin? * Yes No
5. Can the Infiltration Basin accommodate the Water Quality freeboard above the WQV elevation (reference Appendix B.1.3.1)? * Yes No
6. Can the Infiltration Basin be designed with interior side slopes no steeper than 1:4(V:H) (may be 1:3 [V:H] with approval by District Maintenance)? * Yes No
7. Can vegetation be established in the Infiltration Basin? ** Yes No
8. Can diversion be designed, constructed, and maintained to bypass flows exceeding the WQV? ** Yes No
9. Can a gravity-fed Maintenance/Emergency Drain be placed? ** Yes No

Design Elements – Infiltration Trench

* **Required** Design Element – (see definition above)

** **Recommended** Design Element – (see definition above)

1. Has a detailed investigation been conducted, including subsurface soil investigation, in-hole conductivity testing and groundwater elevation determination? (This report must be completed for PS&E level design.) * Yes No
2. Is the surrounding soil within Hydrologic Soil Groups (HSG) Types A or B? * Yes No
3. Is the volume of the Infiltration Trench equal to at least the 2.85x the WQV, while maintaining a drawdown time of ≤ 72 hours? (Note: the WQV must be $\geq 4,356 \text{ ft}^3$ [0.1 acre-feet], unless the District/Regional NPDES Coordinator will allow a volume between $2,830 \text{ ft}^3$ and $4,356 \text{ ft}^3$ to be considered.) * Yes No
4. Is the depth of the Infiltration Trench ≤ 13 ft, and is the depth $<$ the width? * Yes No
5. Can an observation well be placed in the trench? * Yes No
6. Can access be provided to the Infiltration Trench? * Yes No
7. Can pretreatment be provided to capture sediment in the runoff (such as using Biofiltration)? * Yes No
8. Can flow diversion be designed, constructed, and maintained to bypass flows exceeding the Water Quality Event? ** Yes No



Checklist T-1, Part 4

9. Can a perimeter curb or similar device be provided (to limit wheel loads upon the trench)? ** Yes No



Treatment BMPs			
Checklist T-1, Part 5			
Prepared by: <u>BN</u>	Date: <u>05-02-08</u>	District-Co-Route: <u>05-MON-68</u>	
PM (KP): <u>6.1/L6.9(3.8/L4.3)</u>	EA: <u>448000</u>		
RWQCB: <u>REGION 3 CENTRAL COAST</u>			

Detention Devices (WILL BE LOOKED AT PS&E PHASE)

Feasibility

1. Is there sufficient head to prevent objectionable backwater conditions in the upstream drainage systems? Yes No

2. 2a) Is the volume of the Detention Device equal to at least the WQV? (Note: the WQV must be $\geq 4,356 \text{ ft}^3$ [0.1 acre-feet]) Yes No

Only answer (b) if the Detention Device is being used also to capture traction sand.

2b) Is the total volume of the Detention Device at least equal to the WQV and the anticipated volume of traction sand, while maintaining a minimum 12 inch freeboard (1 ft)? Yes No

3. Is basin invert ≥ 10 ft above seasonally high groundwater or can it be designed with an impermeable liner? (Note: If an impermeable liner is used, the seasonally high groundwater elevation must not encroach within 12 inches of the invert.) Yes No

If No to any question above, then Detention Devices are not feasible.

4. Does adequate area exist within the right-of-way to place Detention Device(s)? Yes No
If Yes, continue to the Design Elements section. If No, continue to Question 5.

5. If adequate area does not exist within right-of-way, can suitable, additional right-of-way be acquired to site Detention Device(s) and how much right-of way would be needed to treat WQV? _____ acres Yes No
If Yes, continue to the Design Elements section. If No, continue to Question 6.

6. If adequate area cannot be obtained, document in Section 5 of the SWDR that the inability to obtain adequate area prevents the incorporation of this Treatment BMP into the project. Complete



Design Elements

* **Required Design Element** – A “Yes” response to these questions is required to further the consideration of this BMP into the project design. Document a “No” response in Section 5 of the SWDR to describe why this Treatment BMP cannot be included into the project design.

** **Recommended Design Element** – A “Yes” response is preferred for these questions, but not required for incorporation into a project design.

- 1. Has the geotechnical integrity of the site been evaluated to determine potential impacts to surrounding slopes due to incidental infiltration? If incidental infiltration through the invert of an unlined detention device is a concern, consider using an impermeable liner. * Yes No
- 2. Has the location of the Detention Device been evaluated for any effects to the adjacent roadway and subgrade? * Yes No
- 3. Can a minimum freeboard of 12 inches be provided above the WQV? * Yes No
- 4. Is an overflow outlet provided? * Yes No
- 5. Is the drawdown time of the Detention Device within 24 to 72 hours? * Yes No
- 6. Is the Detention Device outlet designed to minimize clogging (minimum outlet orifice diameter of 0.5 inches)? * Yes No
- 7. Are the inlet and outlet structures designed to prevent scour and re-suspension of settled materials, and to enhance quiescent conditions? * Yes No
- 8. Can vegetation be established in an earthen basin at the invert and on the side slopes for erosion control and to minimize re-suspension? Note: Detention Basins may be lined, in which case no vegetation would be required for lined areas. * Yes No
- 9. Has sufficient access for Maintenance been provided? * Yes No
- 10. Is the side slope 1:4 (V:H) or flatter for interior slopes? **
(Note: Side slopes up to 1:3 (V:H) allowed with approval by District Maintenance.) Yes No
- 11. If significant sediment is expected from nearby slopes, can the Detention Device be designed with additional volume equal to the expected annual loading? ** Yes No
- 12. Is flow path as long as possible (\geq 2:1 length to width ratio at WQV elevation is recommended)? ** Yes No



Treatment BMPs			
Checklist T-1, Part 6			
Prepared by: <u>BN</u>	Date: <u>05-02-08</u>	District-Co-Route: <u>05-MON-68</u>	
PM (KP): <u>6.1/L6.9(3.8/L4.3)</u>	EA: <u>448000</u>		
RWQCB: <u>REGION 3 CENTRAL COAST</u>			

Gross Solids Removal Devices (GSRDs) (NOT APPLICABLE FOR THE PROJECT)

Feasibility

1. Is the receiving water body downstream of the tributary area to the proposed GSRD on a 303(d) list or has a TMDL for litter been established? Yes No
2. Are the devices sized for flows generated by the peak drainage facility design event or can peak flow be diverted? Yes No
3. Are the devices sized to contain gross solids (litter and vegetation) for a period of one year? Yes No
4. Is there sufficient access for maintenance and large equipment (vacuum truck)? Yes No

If No to any question above, then Gross Solids Removal Devices are not feasible. Note that Biofiltration Systems, Infiltration Devices, Detention Devices, Dry Weather Flow Diversion, MCTT, Media Filters, and Wet Basins may be considered for litter capture, but consult with District/Regional NPDES if proposed to meet a TMDL for litter.

5. Does adequate area exist within the right-of-way to place Gross Solids Removal Devices?
If Yes, continue to Design Elements section. If No, continue to Question 6. Yes No
6. If adequate area does not exist within right-of-way, can suitable, additional right-of-way be acquired to site Gross Solids Removal Devices and how much right-of-way would be needed? _____ acres
If Yes, continue to the Design Elements section. If No, continue to Question 7. Yes No
7. If adequate area cannot be obtained, document in Section 5 of the SWDR that the inability to obtain adequate area prevents the incorporation of this Treatment BMP into the project. Complete



Design Elements – Linear Radial Device

*** Required Design Element** – A “Yes” response to these questions is required to further the consideration of this BMP into the project design. Document a “No” response in Section 5 of the SWDR to describe why this Treatment BMP cannot be included into the project design.

**** Recommended Design Element** – A “Yes” response is preferred for these questions, but not required for incorporation into a project design.

- 1. Does sufficient hydraulic head exist to place the Linear Radial GSRD? * Yes No
- 2. Was the litter accumulation rate of 10 ft³/ac/yr (or a different rate recommended by Maintenance) used to size the device? * Yes No
- 3. Were the standard detail sheets used for the layout of the devices? **
If No, consult with Headquarters Office of Storm Water Management and District/Regional NPDES. Yes No
- 4. Is the maximum depth of the storage within 10 ft of the ground surface, or another depth as required by District Maintenance? * Yes No

Design Elements – Inclined Screen

*** Required Design Element** – A “Yes” response to these questions is required to further the consideration of this BMP into the project design. Document a “No” response in Section 5 of the SWDR to describe why this Treatment BMP cannot be included into the project design.

**** Recommended Design Element** – A “Yes” response is preferred for these questions, but not required for incorporation into a project design.

- 1. Does sufficient hydraulic head exist to place the Inclined Screen GSRD? * Yes No
- 2. Was the litter accumulation rate of 10 ft³/ac/yr (or a different rate recommended by Maintenance) used to size the device? * Yes No
- 3. Were the standard details sheets used for the layout of the devices? **
If No, consult with Headquarters Office of Storm Water Management and District NPDES. Yes No
- 4. Is the maximum depth of the storage within 10 ft of the ground surface, or another depth as required by District Maintenance? * Yes No



Treatment BMPs			
Checklist T-1, Part 7			
Prepared by: <u>BN</u>	Date: <u>05-02-08</u>	District-Co-Route: <u>05-MON-68</u>	
PM (KP): <u>6.1/L6.9(3.8/L4.3)</u>	EA: <u>448000</u>		
RWQCB: <u>REGION 3 CENTRAL COAST</u>			

Traction Sand Traps (NOT APPLICABLE FOR THIS PROJECT)

Feasibility

1. Can a Detention Device be sized to capture the estimated traction sand and the WQV from the tributary area?
If Yes, then a separate Traction Sand Trap may not be necessary. Coordinate with the District/Regional Storm Water Coordinator and also complete Checklist T-1, Part 5. Yes No

2. Is the Traction Sand Trap proposed for a site where sand or other traction enhancing substances are applied to the roadway at least twice per year? Yes No

3. Is adequate space provided for Maintenance staff and equipment access for annual cleanout? Yes No

4. Has the local RWQCB agreed that the proposed Traction Sand Trap would not be classified as a regulated underground injection well? Yes No

5. If the answer to any one of Questions 2, 3 or 4 is No, then a Traction Sand Trap is not feasible.

6. Does adequate area exist within the right-of-way to place Traction Sand Traps?
If Yes, continue to Design Elements section. If No, continue to Question 6. Yes No

7. If adequate area does not exist within right-of-way, can suitable, additional right-of-way be acquired to site Traction Sand Traps and how much right-of way would be needed? _____ acres Yes No
If Yes, continue to the Design Elements section. If No, continue to Question 7.

8. If adequate area cannot be obtained, document in Section 5 of the SWDR that the inability to obtain adequate area prevents the incorporation of this Treatment BMP into the project. Complete

Design Elements

*** Required Design Element** – A “Yes” response to these questions is required to further the consideration of this BMP into the project design. Document a “No” response in Section 5 of the SWDR to describe why this Treatment BMP cannot be included into the project design.

**** Recommended Design Element** – A “Yes” response is preferred for these questions, but not required for incorporation into a project design.

1. Was the local Caltrans Maintenance Station contracted to provide the amount of traction sand used annually at the location? * (Detention Device or CMP type) Yes No
List application rate reported. _____ yd³

2. Does the Traction Sand Trap have enough volume to store settled sand over the winter using the formula presented in Appendix B, Section B.5? * (Detention Device or CMP type) Yes No

3. Is the invert of the Traction Sand Trap a minimum of 3 ft above seasonally high groundwater? * (CMP type) Yes No

4. Is the maximum depth of the storage within 10 ft of the ground surface, or another depth as required by District Maintenance? * (CMP type) Yes No

5. Has the District/Regional NPDES Storm Water Coordinator been contacted to ensure that the traction sand trap is not classified as a regulated underground injection well? * (CMP type) Yes No

6. Can peak flow be diverted around the device? ** (CMP type) Yes No

7. Within the tributary area, have the unstabilized areas (that would contribute sediment in addition to traction sand) been minimized as much as possible? ** (Detention Device or CMP type) Yes No

8. Is 6 inches separation provided between the top of the captured traction sand and the outlet from the device, in order to minimize re-suspension of the solids? ** (CMP type) Yes No



Treatment BMPs			
Checklist T-1, Part 8			
Prepared by: <u>BN</u>	Date: <u>05-02-08</u>	District-Co-Route: <u>05-MON-68</u>	
PM (KP): <u>6.1/L6.9(3.8/L4.3)</u>	EA: <u>448000</u>		
RWQCB: <u>REGION 3 CENTRAL COAST</u>			

Media Filters (WILL BE LOOKED AT PS&E PHASE)

Caltrans has approved two types of Media Filter: Austin Sand Filters and Delaware Filters. Austin Sand filters are typically designed for larger drainage areas, while Delaware Filters are typically designed for smaller drainage areas. The Austin Sand Filter is constructed with an open top and may have a concrete or earthen invert, while the Delaware is always constructed as a vault. See Appendix B, Media Filters, for a further description of Media Filters.

Feasibility – Austin Sand Filter

1. Is the volume of the Austin Sand Filter equal to at least the WQV using a 40 to 48 hour drawdown? (Note: the WQV must be $\geq 4,356 \text{ ft}^3$ [0.1 acre-feet]) Yes No

2. Is there sufficient hydraulic head to operate the device (minimum 3 ft between the inflow and outflow chambers)? Yes No

3. If initial chamber has an earthen bottom, is initial chamber invert ≥ 3 ft above seasonally high groundwater? Yes No

4. If a vault is used for either chamber, is the level of the concrete base of the vault above seasonally high groundwater or is a special design provided? Yes No

If No to any question above, then an Austin Sand Filter is not feasible.

5. Does adequate area exist within the right-of-way to place an Austin Sand Filter(s)? Yes No
 If Yes, continue to Design Elements sections. If No, continue to Question 6.

6. If adequate area does not exist within right-of-way, can suitable, additional right-of-way be acquired to site the device and how much right-of way would be needed to treat WQV? _____ acres Yes No
 If Yes, continue to the Design Elements section.
 If No, continue to Question 7.

7. If adequate area cannot be obtained, document in Section 5 of the SWDR that the inability to obtain adequate area prevents the incorporation of this Treatment BMP into the project. Complete

If an Austin Sand Filter meets these feasibility requirements, continue to the Design Elements – Austin Sand Filter below.



Feasibility- Delaware Filter

1. Is the volume of the Delaware Filter equal to at least the WQV using a 40 to 48 hour drawdown? (Note: the WQV must be $\geq 4,356 \text{ ft}^3$ [0.1 acre-feet], consult with District/Regional NPDES if a lesser volume is under consideration.) Yes No
2. Is there sufficient hydraulic head to operate the device (minimum 3 ft between the inflow and outflow chambers)? Yes No
3. Would a permanent pool of water be allowed by the local vector control agency? Yes No

If No to any question, then a Delaware Filter is not feasible

4. Does adequate area exist within the right-of-way to place a Delaware Filter (s)?
If Yes, continue to Design Elements sections. If No, continue to Question 5. Yes No
5. If adequate area does not exist within right-of-way, can suitable, additional right-of-way be acquired to site the device and how much right-of way would be needed to treat WQV? _____ acres Yes No
If Yes, continue to the Design Elements section. If No, continue to Question 6.
6. If adequate area cannot be obtained, document in Section 5 of the SWDR that the inability to obtain adequate area prevents the incorporation of this Treatment BMP into the project. Complete

If a Delaware Filter is still under consideration, continue to the Design Elements – Delaware Filter section.

Design Elements – Austin Sand Filter

* **Required Design Element** – A “Yes” response to these questions is required to further the consideration of this BMP into the project design. Document a “No” response in Section 5 of the SWDR to describe why this Treatment BMP cannot be included into the project design.

** **Recommended Design Element** – A “Yes” response is preferred for these questions, but not required for incorporation into a project design.

1. Is the drawdown time of the 2nd chamber 24 hours? * Yes No
2. Is access for Maintenance vehicles provided to the Austin Sand Filter? * Yes No
3. Is a bypass/overflow provided for storms > WQV? * Yes No
4. Is the flow path length to width ratio for the sedimentation chamber of the “full” Austin Sand Filter $\geq 2:1$? ** Yes No
5. Can pretreatment be provided to capture sediment and litter in the runoff (such as using biofiltration)? ** Yes No
6. Can the Austin Sand Filter be placed using an earthen configuration? **
If No, go to Question 9. Yes No



7. Is the Austin Sand Filter invert separated from the seasonally high groundwater table by ≥ 10 ft? * Yes No
If No, design with an impermeable liner.
8. Are side slopes of the earthen chamber 1:3 (V:H) or flatter? * Yes No
9. Is maximum depth ≤ 13 ft below ground surface? * Yes No
10. Can the Austin Sand Filter be placed in an offline configuration? ** Yes No

Design Elements – Delaware Filter

* **Required Design Element** – A “Yes” response to these questions is required to further the consideration of this BMP into the project design. Document a “No” response in Section 5 of the SWDR to describe why this Treatment BMP cannot be included into the project design.

** **Recommended Design Element** – A “Yes” response is preferred for these questions, but not required for incorporation into a project design.

1. Can the first chamber be sized for the WQV? * Yes No
2. Is the drawdown time of the 2nd chamber between 40 and 48 hours? * Yes No
3. Is access for Maintenance vehicles provided to the Delaware Filter? * Yes No
4. Is a bypass/overflow provided for storms > WQV? ** Yes No
5. Can pretreatment be provided to capture sediment and litter in the runoff (such as using biofiltration)? ** Yes No
6. Can the Delaware Filter be placed in an offline configuration? ** Yes No
7. Is maximum depth ≤ 13 ft below ground surface? * Yes No



Treatment BMPs			
Checklist T-1, Part 9			
Prepared by: <u>BN</u>	Date: <u>05-02-08</u>	District-Co-Route: <u>05-MON-68</u>	
PM (KP): <u>6.1/L6.9(3.8/L4.3)</u>	EA: <u>448000</u>		
RWQCB: <u>REGION 3 CENTRAL COAST</u>			

MCTT (Multi-chambered Treatment Train) (WILL BE LOOKED AT PS&E PHASE)

Feasibility

1. Is the proposed location for the MCTT located to serve a "critical source area" (i.e. vehicle service facility, parking area, paved storage area, or fueling station)? Yes No
2. Is the WQV $\geq 4,356 \text{ ft}^3$ (0.1 acre-foot)? Yes No
3. Is there sufficient hydraulic head (typically ≥ 6 feet) to operate the device? Yes No
4. Would a permanent pool of water be allowed by the local vector control agency?
If No to any question above, then an MCTT is not feasible. Yes No
5. Does adequate area exist within the right-of-way to place an MCTT(s)?
If Yes, continue to Design Elements sections. If No, continue to Question 6. Yes No
6. If adequate area does not exist within right-of-way, can suitable, additional right-of-way be acquired to site the device and how much right-of way would be needed to treat WQV? _____ acres Yes No
If Yes, continue to Design Elements section. If No, continue to Question 7.
7. If adequate area cannot be obtained, document in Section 5 of the SWDR that the inability to obtain adequate area prevents the incorporation of this Treatment BMP into the project. Complete

Design Elements

* **Required Design Element** – A "Yes" response to these questions is required to further the consideration of this BMP into the project design. Document a "No" response in Section 5 of the SWDR to describe why this Treatment BMP cannot be included into the project design.

** **Recommended Design Element** – A "Yes" response is preferred for these questions, but not required for incorporation into a project design.

1. Is the maximum depth of the 3rd chamber ≤ 13 ft below ground surface and has Maintenance accepted this depth? * Yes No
2. Is the drawdown time in the 3rd chamber between 24 and 48 hours? * Yes No
3. Is access for Maintenance vehicles provided to all chambers of the MCTT? * Yes No
4. Is there sufficient hydraulic head to operate the device? * Yes No
5. Has a bypass/overflow been provided for storms $> \text{WQV}$? * Yes No
6. Can pretreatment be provided to capture sediment and litter in the runoff (such as using biofiltration)? ** Yes No



Treatment BMPs			
Checklist T-1, Part 10			
Prepared by:	BN	Date:	05-02-08
		District-Co-Route:	05-MON-68
PM (KP):	6.1/L6.9(3.8/L4.3)	EA:	44800
RWQCB:	REGIONAL 3 CENTRAL COAST		

Wet Basin (NOT APPLICABLE FOR THIS PROJECT)

Feasibility

1. Is the volume of the Wet Basin above the permanent pool equal to at least the WQV using a 24 to 72 hour drawdown (40 to 48 hour drawdown preferred)? (Note: the WQV must be $\geq 4,356 \text{ ft}^3$ [0.1 acre-feet] and the permanent pool must be at least 3x the WQV.) Yes No

2. Is a permanent source of water available in sufficient quantities to maintain the permanent pool for the Wet Basin? Yes No

3. Is proposed site in a location where naturally occurring wetlands do not exist? Yes No

- Answer either question 4 or question 5:

4. For Wet Basins with a proposed invert above the seasonally high groundwater, are NRCS Hydrologic Soil Groups [HSG] C and D at the proposed invert elevation, or can an impermeable liner be used? (Note: If an impermeable liner is used, the seasonally high groundwater elevation must not encroach within 12 inches of the invert.) Yes No

5. For Wet Basins with a proposed invert below the groundwater table: Can written approval from the local Regional Water Quality Control Board be obtained to place the Wet Basin in direct hydraulic connectivity to the groundwater? Yes No

6. Is Water Quality freeboard provided ≥ 1 foot? Yes No

7. Is the maximum impoundment volume < 14.75 acre-feet? Yes No

8. Would a permanent pool of water be allowed by the local vector control agency? Yes No
If No to any question above, then a Wet Basin is not feasible.

9. Is the maximum basin width ≤ 49 ft as suggested in Section B.10.2? Yes No
If No, consult with the local vector control agency and District Maintenance.

10. Does adequate area exist within the right-of-way to place a Wet Basin? Yes No
If Yes, continue to Design Elements sections.
If No, continue to Question 10.



11. If adequate area does not exist within right-of-way, can suitable, additional right-of-way be acquired to site the device and how much right-of way would be needed to treat WQV? _____ acres Yes No
12. If Yes, continue to Design Elements section.
If No, continue to Question 8.
13. If adequate area cannot be obtained, document in Section 5 of the SWDR that the inability to obtain adequate area prevents the incorporation of this Treatment BMP into the project. Complete

Design Elements

* **Required Design Element** – A “Yes” response to these questions is required to further the consideration of this BMP into the project design. Document a “No” response in Section 5 of the SWDR to describe why this Treatment BMP cannot be included into the project design.

** **Recommended Design Element** – A “Yes” response is preferred for these questions, but not required for incorporation into a project design.

1. Can a controlled outlet and an overflow structure be designed for storm events larger than the Water Quality event? * Yes No
2. Is access for Maintenance vehicles provided? * Yes No
3. Is the drawdown time for the WQV between 24 and 72 hours? * Yes No
4. Has appropriate vegetation been selected for each hydrologic zone? * Yes No
5. Can all design elements required by the local vector control agency be incorporated? * Yes No
6. Has a minimum flow path length-to-width ration of at least 2:1 been provided? ** Yes No
7. Has an upstream bypass been provided for storms > WQV? ** Yes No
8. Can pretreatment be provided to capture sediment and litter in the runoff (such as using biofiltration, or a forebay)? ** Yes No
9. Can public access be restricted using a fence if proposed at locations accessible on foot by the public? ** Yes No
10. Is the maximum depth ≤ 10 ft? * Yes No



Construction Site BMPs			
Checklist CS-1, Part 1			
Prepared by: <u>BN</u>	Date: <u>05-02-08</u>	District-Co-Route: <u>05-MON-68</u>	
PM (KP): <u>6.1/L6.9(3.8/L4.3)</u>	EA: <u>448000</u>		
RWQCB: <u>REGION 3 CENTRAL COAST</u>			

Soil Stabilization (WILL BE LOOKED AT PS&E PHASE)

General Parameters

1. How many rainy seasons are anticipated between beginning and end of construction? _____
2. What is the total disturbed soil area for the project? (ac) _____
 - (a) How much of the project DSA consists of slopes 1V:4H or flatter? (ac) _____
 - (b) How much of the project DSA consists of 1V:4H < slopes < 1V:2H? (ac) _____
 - (c) How much of the project DSA consists of slopes 1V:2H and steeper? (ac) _____
 - (d) How much of the project DSA consists of slopes with slope lengths longer than 20 ft? (ac) _____
3. What rainfall area does the project lie within? (Refer to Table 2-1 of the Construction Site Best Management Practices Manual) _____
4. Review the required combination of temporary soil stabilization and temporary sediment controls and barriers for area, slope inclinations, rainy and non-rainy season, and active and non-active disturbed soil areas. (Refer to Tables 2-2, and 2-3 of the Construction Site Best Management Practices Manual for Rainfall Area requirements.) Complete

Scheduling (SS-1)

5. Does the project have a duration of more than one rainy season and have disturbed soil area in excess of 25 acres? Yes No
 - (a) Include multiple mobilizations (Move-in/Move-out) as a separate contract bid line item to implement permanent erosion control or revegetation work on slopes that are substantially complete. (Estimate at least 6 mobilizations for each additional rainy season. Designated Construction Representative may suggest an alternate number of mobilizations.) Complete
 - (b) Edit Order of Work specifications for permanent erosion control or revegetation work to be implemented on slopes that are substantially complete. Complete
 - (c) Edit permanent erosion control or revegetation specifications to require seeding and planting work to be performed when optimal. Complete



Preservation of Existing Vegetation (SS-2)

6. Do Environmentally Sensitive Areas (ESAs) exist within or adjacent to the project limits? (Verify the completion of DPP-1, Part 5) Yes No
- (a) Verify the protection of ESAs through delineation on all project plans. Complete
- (b) Protect from clearing and grubbing and other construction disturbance by enclosing the ESA perimeter with high visibility plastic fence or other BMP. Complete
7. Are there areas of existing vegetation (mature trees, native vegetation, landscape planting, etc.) that need not be disturbed by project construction? Will areas designated for proposed treatment BMPs need protection (infiltration characteristics, vegetative cover, etc.)? (Coordinate with District Environmental and Construction to determine limits of work necessary to preserve existing vegetation to the maximum extent practicable.) Yes No
- (a) Designate as outside of limits of work (or designate as ESAs) and show on all project plans. Complete
- (b) Protect with high visibility plastic fence or other BMP. Complete
8. If yes for 6, 7, or both, then designate ESA fencing as a separate contract bid line item, if not already incorporated as part of design pollution prevention work (See DPP-1, Part 5). Complete

Slope Protection

9. Provide a soil stabilization BMP(s) appropriate for the DSA, slope steepness, slope length, and soil erodibility. (Consult with District/Regional Landscape Architect.)
- (a) Select SS-3 (Hydraulic Mulch), SS-4 (Hydroseeding), SS-5 (Soil Binders), SS-6 (Straw Mulch), SS-7 (Geotextiles, RECPs, Etc.), SS-8 (Wood Mulching), other BMPs or a combination to cover the DSA throughout the project's rainy season. Complete
- (b) Increase the quantities by 25% for each additional rainy season. (Designated Construction Representative may suggest an alternate increase.) Complete
- (c) Designate as a separate contract bid line item. Complete

Slope Interrupter Devices

10. Provide slope interrupter devices for all slopes with slope lengths equal to or greater than of 20 ft in length. (Consult with District/Regional Landscape Architect and Designated Construction Representative.)



- (a) Select SC-5 (Fiber Rolls) or other BMPs to protect slopes throughout the project's rainy season. Complete
- (b) For slope inclination of 1V:4H and flatter, SC-5 (Fiber Rolls) or other BMPs shall be placed along the contour and spaced 20 ft on center. Complete
- (c) For slope inclination between 1V:4H and 1V:2H, SC-5 (Fiber Rolls) or other BMPs shall be placed along the contour and spaced 15 ft on center. Complete
- (d) For slope inclination of 1V:2H and greater, SC-5 (Fiber Rolls) or other BMPs shall be placed along the contour and spaced 10 ft on center. Complete
- (e) Increase the quantities by 25% for each additional rainy season. (Designated Construction Representative may suggest alternate increase.) Complete
- (f) Designate as a separate contract bid line item. Complete

Channelized Flow

- 11. Identify locations within the project site where concentrated flow from stormwater runoff can erode areas of soil disturbance. Identify locations of concentrated flow that enters the site from outside of the right-of-way (off-site run-on). Complete
 - (a) Utilize SS-7 (Geotextiles, RECPs, etc.), SS-9 (Earth Dikes/Swales, Ditches), SS-10 (Outlet Protection/Velocity Dissipation), SS-11 (Slope Drains), SC-4 (Check Dams), or other BMPs to convey concentrated flows in a non-erosive manner. Complete
 - (b) Designate as a separate contract bid line item. Complete



Construction Site BMPs			
Checklist CS-1, Part 2			
Prepared by: <u>BN</u>	Date: <u>05-02-08</u>	District-Co-Route: <u>05-MON-68</u>	
PM (KP): <u>6.1/L6.9(3.8/L4.3)</u>	EA: <u>448000</u>		
RWQCB: <u>REGION 3 CENTRAL COAST</u>			

Sediment Control (WILL BE LOOKED AT PS&E PHASE)

Perimeter Controls - Run-off Control

1. Is there a potential for sediment laden sheet and concentrated flows to discharge offsite from runoff cleared and grubbed areas, below cut slopes, embankment slopes, etc.? Yes No
 - (a) Select linear sediment barrier such as SC-1 (Silt Fence), SC-5 (Fiber Rolls), SC-6 (Gravel Bag Berm), SC-8 (Sand Bag Barrier), SC-9 (Straw Bale Barrier), or a combination to protect wetlands, water courses, roads (paved and unpaved), construction activities, and adjacent properties. (Coordinate with District Construction for selection and preference of linear sediment barrier BMPs.) Complete
 - (b) Increase the quantities by 25% for each additional rainy season. (Designated Construction Representative may suggest an alternate increase.) Complete
 - (c) Designate as a separate contract bid line item. Complete

Perimeter Controls - Run-on Control

2. Do locations exist where sheet flow upslope of the project site and where concentrated flow upstream of the project site may contact DSA and construction activities? Yes No
 - (a) Utilize linear sediment barriers such as SS-9 (Earth Dike/Drainage Swales and Lined Ditches), SC-5 (Fiber Rolls), SC-6 (Gravel Bag Berm), SC-8 (Sand Bag Barrier), SC-9 (Straw Bale Barrier), or other BMPs to convey flows through and/or around the project site. (Coordinate with District Construction for selection and preference of perimeter control BMPs.) Complete
 - (b) Designate as a separate contract bid line item. Complete



Storm Drain Inlets

3. Do existing or proposed drainage inlets exist within the project limits? Yes No
- (a) Select SC-10 (Storm Drain Inlet Protection) to protect municipal storm drain systems or receiving waters wetlands at each drainage inlet. (Coordinate with District Construction for selection and preference of inlet protection BMPs.) Complete
- (b) Designate as a separate contract bid line item. Complete
4. Can existing or proposed drainage inlets utilize an excavated sediment trap as described in SC-10 (Storm Drain Inlet Protection- Type 2)? Yes No
- (a) Include with other types of SC-10 (Storm Drain Inlet Protection). Complete

Sediment/Desilting Basin (SC-2)

5. Does the project lie within a Rainfall Area where the required combination of temporary soil stabilization and sediment control BMPs includes desilting basins? (Refer to Tables 2-1, 2-2, and 2-3 of the Construction Site Best Management Practices Manual for Rainfall Area requirements.) Yes No
- (a) Consider feasibility for desilting basin allowing for available right-of-way within the project limits, topography, soil type, disturbed soil area within the watershed, and climate conditions. Document if the inclusion of sediment/desilting basins is infeasible. Complete
- (b) If feasible, design desilting basin(s) per the guidance in SC-2 Sediment/Desilting Basins of the Construction Site BMP Manual to maximize capture of sediment-laden runoff. Complete
- Designate as a separate contract bid item. Complete
6. Will the project benefit from the early implementation of proposed permanent Treatment BMPs? (Coordinate with District Construction.) Yes No
- (a) Edit Order of Work specifications for permanent treatment BMP work to be implemented in a manner that will allow its use as a construction site BMP. Complete

Sediment Trap (SC-3)

7. Can sediment traps be located to collect channelized runoff from disturbed soil areas prior to discharge? Yes No
- (a) Design sediment traps in accordance with the Construction Site BMP Manual. Complete
- (b) Designate as a separate contract bid line item. Complete



Construction Site BMPs		
Checklist CS-1, Part 3		
Prepared by: <u>BN</u>	Date: <u>05-02-08</u>	District-Co-Route: <u>05-MON-68</u>
PM (KP): <u>6.1/L6.9(3.8/L4.3)</u>	EA: <u>448000</u>	
RWQCB: <u>REGION 3 CENTRAL COAST</u>		

Tracking Controls (WILL BE LOOKED AT PS&E PHASE)

Stabilized Construction Entrance/Exit (TC-1)

1. Are there points of entrance and exit from the project site to paved roads where mud and dirt could be transported offsite by construction equipment? (Coordinate with District Construction for selection and preference of tracking control BMPs.) Yes No
- (a) Identify and designate these entrance/exit points as stabilized construction entrances (TC-1). Complete
- (b) Designate as a separate contract bid line item. Complete

Tire/Wheel Wash (TC-3)

2. Are site conditions anticipated that would require additional or modified tracking controls such as entrance/outlet tire wash? (Coordinate with District Construction.) Yes No
- Designate as a separate contract bid line item. Complete

Stabilized Construction Roadway (TC-2)

3. Are temporary access roads necessary to access remote construction activity locations or to transport materials and equipment? (In addition to controlling dust and sediment tracking, access roads limit impact to sensitive areas by limiting ingress, and provide enhanced bearing capacity.) (Coordinate with District Construction.) Yes No
- (a) Designate these temporary access roads as stabilized construction roadways (TC-2). Complete
- (b) Designate as a separate contract bid line item. Complete

Street Sweeping and Vacuuming (SC-7)

9. Is there a potential for tracked sediment or construction related residues to be transported offsite and deposited on public or private roads? (Coordinate with District Construction for preference of including street sweeping and vacuuming with tracking control BMPs.) Yes No
- Designate as a separate contract bid line item. Complete



Construction Site BMPs			
Checklist CS-1, Part 4			
Prepared by: <u>BN</u>	Date: <u>05-02-08</u>	District-Co-Route: <u>05-MON-68</u>	
PM (KP): <u>6.1/L6.9(3.8/L4.3)</u>	EA: <u>448000</u>		
RWQCB: <u>REGION 3 CENTRAL COAST</u>			

Wind Erosion Controls (WILL BE LOOKED AT PS&E PHASE)

Wind Erosion Control (WE-1)

1. Is the project located in an area where standard dust control practices in accordance with Standard Specifications, Section 10: Dust Control, are anticipated to be inadequate during construction to prevent the transport of dust offsite by wind? (Note: Dust control by water truck application is paid for through the various items of work. Dust palliative, if it is included, is paid for as a separate item.) Yes No
 - (a) Select SS-3 (Hydraulic Mulch), SS-4 (Hydroseeding), SS-5 (Soil Binders), SS-7 (Geotextiles, Plastic Covers, & Erosion Control Blankets/Mats), SS-8 (Wood Mulching) or a combination to cover the DSA subject to wind erosion year-round, especially when significant wind and dry conditions are anticipated during project construction. (Coordinate with District Construction for selection and preference of wind erosion control BMPs.) Complete
 - (b) Designate as a separate contract bid line item. Complete



Construction Site BMPs			
Checklist CS-1, Part 5			
Prepared by:	BN	Date:	05-02-08
		District-Co-Route:	05-MON-68
PM (KP):	6.1/L6.9(3.8/L4.3)	EA:	448000
RWQCB:	REGION 3 CENTRAL COAST		

Non-Storm Water Management (WILL BE LOOKED AT PS&E PHASE)

Temporary Stream Crossing (NS-4) & Clear Water Diversion (NS-5)

1. Will construction activities occur within a waterbody or watercourse such as a lake, wetland, or stream? (Coordinate with District Construction for selection and preference for stream crossing and clear water diversion BMPs.) Yes No
 - (a) Select from types offered in NS-4 (Temporary Stream Crossing) to provide access through watercourses consistent with permits and agreements.¹ Complete
 - (b) Select from types offered in NS-5 (Clear Water Diversion) to divert watercourse consistent with permits and agreements.¹ Complete
 - (c) Designate as a separate contract bid line item(s). Complete

Other Non-Storm Water Management BMPs

2. Are construction activities anticipated that will generate wastes or residues with the potential to discharge pollutants? Yes No
 - (a) Identify potential pollutants associated with the anticipated construction activity and select the corresponding BMP such as NS-1 (Water Conservation Practices), NS-2 (Dewatering Operations), NS-3 (Paving and Grinding Operations), NS-7 (Potable Water/Irrigation), NS-8 (Vehicle and Equipment Cleaning), NS-9 (Vehicle and Equipment Fueling), NS-10 (Vehicle and Equipment Maintenance), NS-11 (Pile Driving Operations), NS-12 (Concrete Curing), NS-13 (Material and Equipment Use Over Water), NS-14 (Concrete Finishing), and NS-15 (Structure Demolition/Removal Over or Adjacent to Water).¹ Complete
 - (b) Verify that costs for non-storm water management BMPs are identified in the contract documents. Designate BMP as a separate contract bid line item if the requirements in Construction Site Management (SSP 07-346) are anticipated to be inadequate or if requested by Construction. Complete

1. Coordinate with District Environmental for consistency with US Army Corps of Engineers 404



permit and Dept. of Fish and Game 1601 Streambed alteration Agreements.



Construction Site BMPs			
Checklist CS-1, Part 6			
Prepared by:	BN	Date:	05-02-08
		District-Co-Route:	05-MON-68
PM (KP):	6.1/L6.9(3.8/L4.3)	EA:	448000
RWQCB:	REGION 3 CENTRAL COAST		

Waste Management & Materials Pollution Control (WILL BE LOOKED AT PS&E PHASE)

Concrete Waste Management (WM-8)

1. Does the project include concrete pours or mortar mixing? Yes No
 - (a) Select from types offered in WM-8 (Concrete Waste Management) to provide concrete washout facilities. In addition, consider portable concrete washouts and vendor supplied concrete waste management services. (Coordinate with District Construction for selection and preference of waste management and materials pollution control BMPs.) Complete
 - (b) Designate as a separate contract bid line item if the quantity of concrete waste and washout are anticipated to exceed 5.2 yd³ or if requested by Construction. Complete

Other Waste Management and Materials Pollution Controls

2. Are construction activities anticipated that will generate wastes or residues with the potential to discharge pollutants? Yes No
 - (a) Identify potential pollutants associated with the anticipated construction activity and select the corresponding BMP such as WM-1 (Material Delivery and Storage), WM-2 (Material Use), WM-4 (Spill Prevention and Control), WM-5 (Solid Waste Management), WM-6 (Hazardous Waste Management), WM-7 (Contaminated Soil Management), WM-9 (Sanitary/Septic Waste Management) and WM-10 (Liquid Waste Management) Complete
 - (b) Verify that costs for waste management and materials pollution control BMPs are identified in the contract documents. Designate BMP as a separate contract bid line item if the requirements in Construction Site Management (SSP 07-346) are anticipated to be inadequate or if requested by Construction. Complete

Temporary Stockpiles (Soil, Materials, and Wastes)

3. Are stockpiles of soil, etc. anticipated during construction? Yes No
 - (a) Select WM-3 (Stockpile Management), SS-3 (Hydraulic Mulch), SS-4 (Hydroseeding), SS-5 (Soil Binders), SS-7 (Geotextiles, RECPs etc.), or a combination as appropriate to cover temporary stockpiles of soil, etc. Complete



- (b) Select linear sediment barrier such as SC-1 (Silt Fence), SC-5 (Fiber Rolls), SC-6 (Gravel Bag Berm), SC-8 (Sand Bag Barrier), SC-9 (Straw Bale Barrier), or a combination to encircle temporary stockpiles of soil, etc. (Coordinate with District Construction for selection and preference of BMPs related to stockpiles.) Complete
- (c) Designate as a separate contract bid line item if the requirements in Construction Site management (SSP 07-346) are anticipated to be inadequate or if requested by Construction. Complete
- 4. Is there a potential for dust and debris from construction material (fill material, etc.) and waste (concrete, contaminated soil, etc.) stockpiles to be transported offsite by wind? Yes No
 - (a) Select SS-7, temporary cover, plastic sheeting or other BMP to cover stockpiles subject to wind erosion year-round, especially when significant wind and dry conditions are anticipated during project construction. (Coordinate with District Construction for selection and preference of wind erosion control BMPs.) Complete
 - (b) Designate as a separate contract bid line item. Complete

